

ASSEMBLY INSTRUCTIONS
FOR
DYNALITE DRAG RACE FRONT HAT KIT, 11.75" DIAMETER SOLID ROTOR
1990 - 2005 ACURA/CIVIC (4 LUG) • 2000 - 2003 CIVIC SI (4 LUG)
2007 - PRESENT HONDA FIT
FOR FACTORY 262 mm DISC SPINDLE

PART NUMBER GROUP

140-8442

**DISC BRAKES SHOULD ONLY BE INSTALLED BY SOMEONE
KNOWLEDGEABLE AND COMPETENT IN THE FUNCTIONING
AND MAINTENANCE OF DISC BRAKES**
READ ALL WARNINGS

WARNING

IT IS THE RESPONSIBILITY OF THE PERSON INSTALLING ANY BRAKE COMPONENT OR KIT TO DETERMINE THE SUITABILITY OF THE COMPONENT OR KIT FOR THAT PARTICULAR APPLICATION. IF YOU ARE NOT SURE HOW TO SAFELY USE THIS BRAKE COMPONENT OR KIT, YOU SHOULD NOT INSTALL OR USE IT. DO NOT ASSUME ANYTHING. IMPROPERLY INSTALLED OR MAINTAINED BRAKES ARE DANGEROUS. IF YOU ARE NOT SURE, GET HELP OR RETURN THE PRODUCT. YOU MAY OBTAIN ADDITIONAL INFORMATION AND TECHNICAL SUPPORT BY CALLING WILWOOD AT (805) 388-1188, OR VISIT OUR WEB SITE AT WWW.WILWOOD.COM. USE OF WILWOOD TECHNICAL SUPPORT DOES NOT GUARANTEE PROPER INSTALLATION. **YOU**, OR THE PERSON WHO DOES THE INSTALLATION MUST KNOW HOW TO PROPERLY USE THIS PRODUCT. IT IS NOT POSSIBLE OVER THE PHONE TO UNDERSTAND OR FORESEE ALL THE ISSUES THAT MIGHT ARISE IN YOUR INSTALLATION.

RACING EQUIPMENT AND BRAKES MUST BE MAINTAINED AND SHOULD BE CHECKED REGULARLY FOR FATIGUE, DAMAGE, AND WEAR.



WARNING

DO NOT OPERATE ANY VEHICLE ON UNTESTED BRAKES!
SEE MINIMUM TEST PROCEDURE WITHIN

ALWAYS UTILIZE SAFETY RESTRAINT SYSTEMS AND ALL OTHER AVAILABLE SAFETY EQUIPMENT WHILE OPERATING THE VEHICLE

IMPORTANT • READ THE DISCLAIMER OF WARRANTY INCLUDED IN THE KIT

NOTE: Some cleaners may stain or remove the finish on brake system components. Test the cleaner on a hidden portion of the component before general use.

Important Notice - Read This First

Before any tear-down or disassembly begins, review the following information:

- Review the wheel clearance diagram (figure 1) to verify that there is adequate clearance with the wheels you will be using with the installation.
- Before any tear-down or disassembly begins, modifications are required to the stock spindle. This includes removing some material from the stock spindle caliper mounting area that will interfere with the assembly of the Wilwood disc brake kit. It is recommended that these modifications be performed by a qualified machine shop. Please refer to the modification procedure and Figure 2 below.
- Front brake kits do not include flex lines. OEM brake lines will not adapt to Wilwood calipers. Check the assembly instructions, or associated components section for brake line recommendations before assembly. In addition, Wilwood offers an extensive listing of brake lines and fittings on our web site: www.wilwood.com.
- Due to OEM production differences and other variations from vehicle to vehicle, the fastener hardware and other components in this kit may not be suitable for a specific application or vehicle.
- It is the responsibility of the purchaser and installer of this kit to verify suitability / fitment of all components and ensure all fasteners and hardware achieve complete and proper engagement. Improper or inadequate engagement can lead to component failure.

General Information and Disassembly Instructions

Installation of this kit should **ONLY** be performed by persons experienced in the installation and proper operation of disc brake systems. Before installation begins, please read the complete procedure thoroughly to familiarize yourself with the process, and double check the following items to ensure a trouble-free installation.

- Make sure this is the correct kit to match the exact make and model year of the vehicle's spindle (i.e., brackets for a 1980 Honda spindle will not fit a 1997 Honda spindle).
- Verify the hat stud pattern in this kit matches the stud pattern of the vehicle's wheels.
- Verify your wheel clearance using Figure 1.
- Inspect the package contents against the parts list to ensure that all components and hardware are included.

Disassembly

- Disassemble the original equipment front brakes:

Raise the front wheels off the ground and support the front suspension according to the vehicle manufacturer's instructions.

Remove the wheel. Disconnect the caliper brake hose from the brake line at the body. Remove the two bolts that hold the stock caliper mounting bracket to the spindle. Lift off the bracket and stock caliper as one unit, then slide off the stock hat and rotor assembly. On some models you may have to unbolt the stock caliper from the caliper bracket before removal.

- Thoroughly clean and de-grease the spindles while removing all nicks or burrs around the spindle and threads.

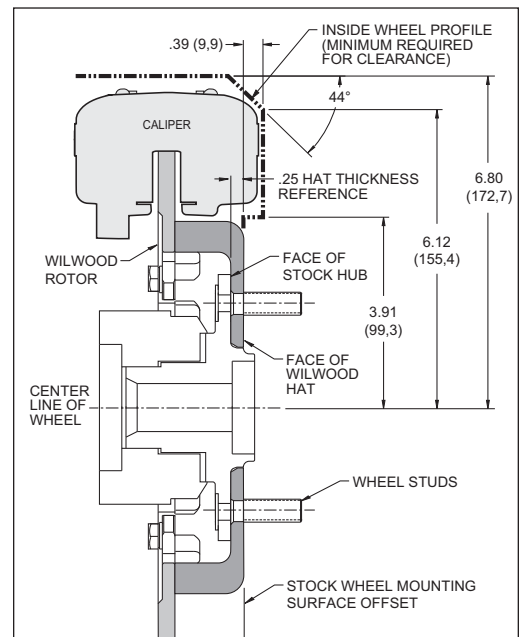

Figure 1. Wheel Clearance Diagram

Spindle Modifications

- These modifications should be performed by a qualified machinist. Refer to Figure 2, right. Only one view of the spindle is shown, but the modifications need to be performed on both spindles.
- Some material must be removed from the caliper mounting lugs on the OE spindle until .19" (4.8mm) remains between a tangent on the outer edge of the bolt hole and the outer edge of the lug. After removal, be sure the area is free of sharp edges or burrs. With the caliper and mount bracket in place, check to be sure there is no interference between the mounting lugs on the spindle and the caliper.

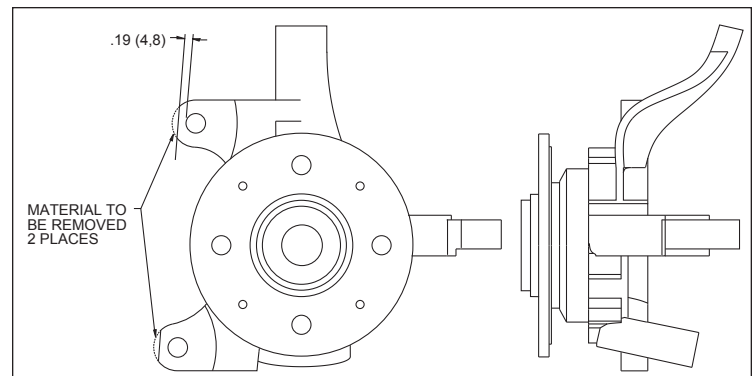

Figure 2. Spindle Modifications

Exploded Assembly Diagram and Parts List

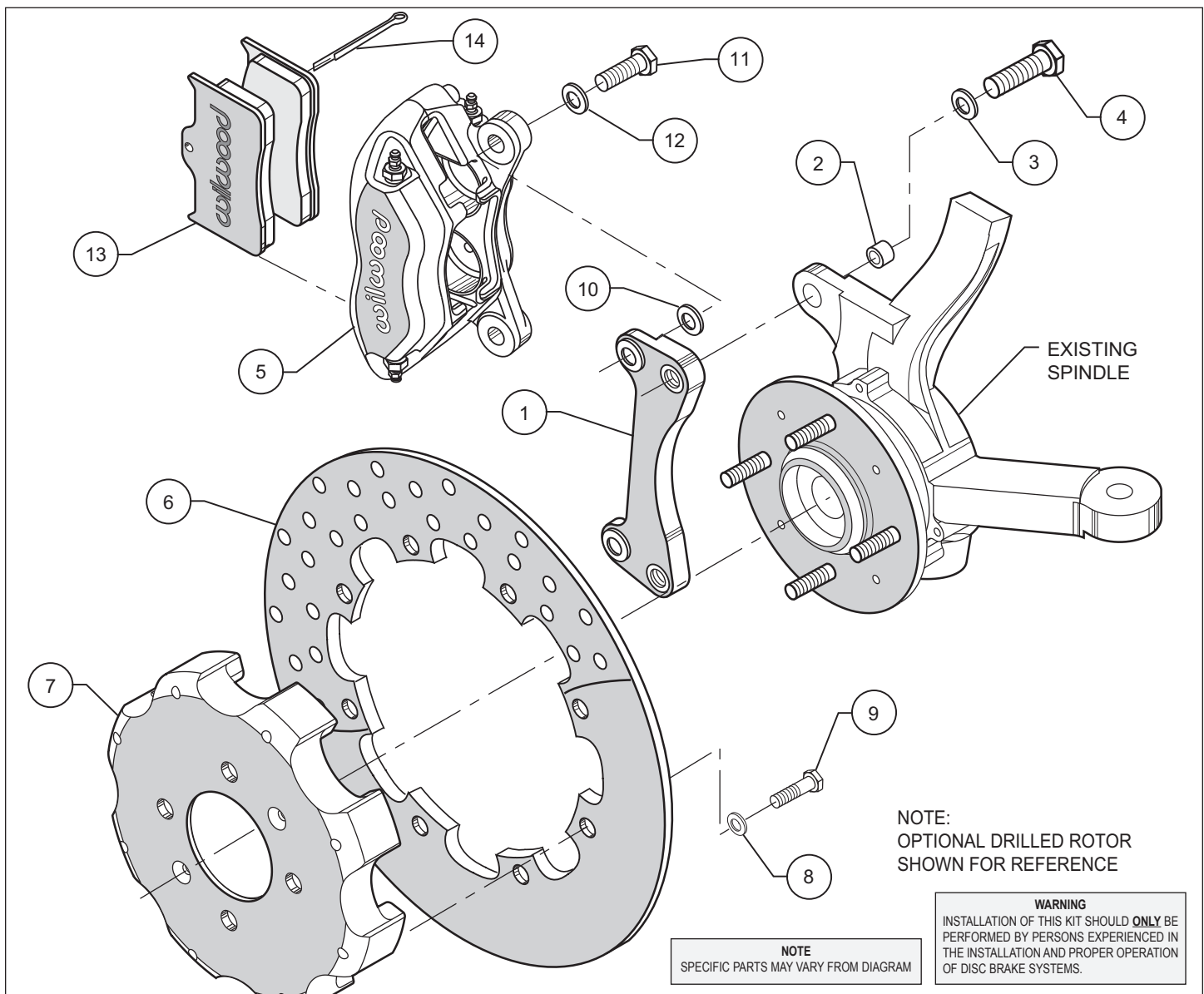

Figure 3. Typical Installation Configuration, Left Hand Application Shown

ITEM NO.	PART NO.	DESCRIPTION	QTY
1	250-8404	Bracket, Caliper Mounting	2
2	300-8406	Sleeve	4
3	240-10190	Washer, .391 I.D. x .625 O.D. x .063 Thick	4
4	230-10024	Bolt, 3/8-24 x 1.00 Long, Hex Head	4
5	120-6808	Caliper, Forged Dynalite	2
6	160-3201	Rotor, .35" Thk x 11.75" Dia, 8 x 7.00" Bolt Circle	2
6A	160-3202	Rotor, Drilled	2
7	170-8405	Hat	2
8	240-10191	Washer, .328 I.D. x .562 O.D. x .063 Thick	16
9	230-8473	Bolt, 5/16-18 x 1.00 Long, Hex Head	16
10	240-1159	Shim Washer, .035 Thick	16
11	230-0228	Bolt, 3/8-24 x 1.25 Long, Hex Head	4
12	240-10190	Washer, .391 I.D. x .625 O.D. x .063 Thick	4
13	150-8850K	Pad, BP-10 Compound, Axle Set	1
14	180-0054S	Pin, Cotter	2
Optional	220-6420	Braided Stainless Steel Hose Kit (Not Included) Years 1990-2000	
Optional	220-6860	Braided Stainless Steel Hose Kit (Not Included) Years 2001-2005	
Optional	220-11790	Braided Stainless Steel Hose Kit (Not Included) Years 2007-Present Honda Fit	

NOTES: Part Number 230-8390 Rotor Bolt Kit, includes part numbers 230-8473 and 240-10191
 Part Number 230-8461 Caliper Bracket Mounting Bolt Kit, includes P/N's 230-10024, 240-10190, and 300-8406
 Part Number 230-0204 Caliper Mounting Bolt Kit, includes P/N's 230-0228, 240-10190 and 240-1159
 Item 6A is an optional item and is included with the "-D" kits. Add "-D" to end of part number when ordering.

Assembly Instructions

Assembly Instructions (numbers in parenthesis refer to the part list/diagram on the preceding page): **CAUTION:** All mounting bolts must fully engage insert nuts. Be sure to check that all bolts are either flush or protruding through flanged side of insert nut after shimming.

•Insert one sleeve (2) each into the holes on the top and bottom of the spindle “ears” where the OEM caliper bracket was removed. Apply red *Loctite*® 271 to the caliper mounting bracket bolt threads (4) before installation of the caliper mounting bracket (1). Install the caliper mounting bracket (1) with the threaded inserts and the beveled bolt holes facing the outside of the vehicle. Slide bolt (4) through washer (3) into the previously installed sleeve (2) from the backside of the spindle. Finger tighten. Repeat for the lower mounting hole. Torque bolts to 30 ft-lb. **NOTE:** Be sure the heads of the caliper bracket (1) insert nuts are facing outward toward the wheel.

•Attach the hat (7) to the rotor (6) using washers (8) and bolts (9) as shown in Figure 3. Using an alternating sequence, remove bolts (9) one at a time, apply red *Loctite*® 271 to bolt threads, and torque to 120-144 in-lb. Safety wire bolts (9) using standard 0.032 inch diameter stainless steel safety wire as shown in Figure 4. Please refer to Wilwood’s data sheet DS-386 (available at www.wilwood.com/Pdf/DataSheets/ds386.pdf) for complete safety wire installation instructions. Slide the rotor/hat assembly onto the spindle. Install three lug nuts (finger tighten) to keep the rotor/hat assembly in place while continuing with the installation.

•**NOTE:** Please reference the caution statement at the beginning of the assembly instructions. Mount the caliper (5) onto the caliper mounting bracket (1) using two bolts (11) and two washers (12). View the rotor (6) through the top of the caliper (5). The rotor (6) should be aligned in the center of the caliper (5). If not, loosen the two bolts (11) and adjust the caliper (5) by using 0.035 inch thick shim washers (10). The shim washers (10) should be placed between the caliper (5) and the caliper mounting bracket (1). Finger tighten and recheck alignment. **NOTE:** The end of the bolt must be flush with or slightly protruding from the head of the clinch nut. See Figure 5. Place spare shims (10) between washer and caliper mounting ear to achieve the proper mounting fastener configuration. Add as many shim washers (10) as necessary to achieve the correct alignment. Always use the same amount of shims on both the top and bottom caliper mounting bolts (11). Loosen the two bolts (11) and apply red *Loctite*® 271 to bolt threads (11) and torque to 30 ft-lb. Safety wire the two bolts (11).

•Install the disc brake pads (13) and secure using cotter pin (14). Repeat this procedure for the other wheel.

•Remove the two lug nuts that were used to hold the rotor/hat assembly in place during caliper installation. Install the wheel and lug nuts, torque to OEM specifications.

•**NOTE:** OEM rubber brake hoses generally cannot be adapted to Wilwood calipers. The caliper inlet fitting is a 1/8-27 NPT. The preferred method is to use steel adapter fittings at the caliper, either straight, 45 or 90 degree and enough steel braided line to allow for full suspension travel and turning radius, lock to lock. **Carefully route lines to prevent contact with moving suspension, brake or wheel components.** Wilwood hose kits are designed for use in many different vehicle applications and it is the installer’s responsibility to properly route and ensure adequate clearance and retention for brake hose components. Wilwood offers a hose kit, P/N 220-6420, which includes hoses, fittings, etc., all in one package for this application.

•Specified brake hose kits may not work with all Years, Makes and Models of vehicle that this brake kit is applicable to, due to possible OEM manufacturing changes during a production vehicle’s life. It is the installer’s responsibility to ensure that all fittings and hoses are the correct size and length, to ensure proper sealing and that they will not be subject to crimping, strain and abrasion from vibration or interference with suspension components, brake rotor or wheel.

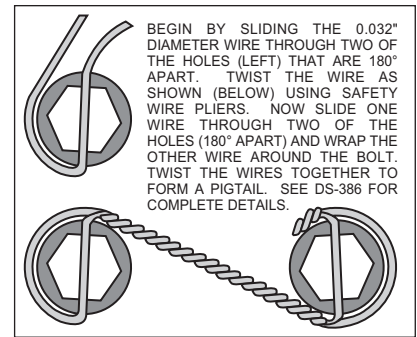

Figure 4. Safety Wire Diagram

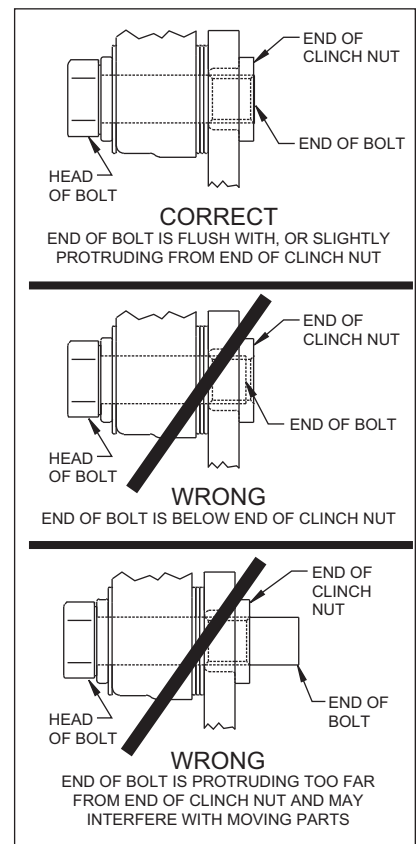

Figure 5. Clinch Nut Engagement Diagram

Assembly Instructions

- In absence of specific instructions for brake line routing, the installer must use his best professional judgment on correct routing and retention of lines to ensure safe operation. Test vehicle brake system per the 'minimum test' procedure stated within this document before driving. After road testing, inspect for leaks and interference. Initially after install and testing, perform frequent checks of the vehicle brake system and lines before driving, to confirm that there is no undue wear or interference not apparent from the initial test. Afterwards, perform periodic inspections for function, leaks and wear in a interval relative to the usage of vehicle.
- Bleed the brake system. Reference the general information and recommendations below for proper bleeding instructions.

Additional Information and Recommendations

• **NOTE:** *With the installation of after market disc brakes, the wheel track may change depending on the application. Check your wheel offset before final assembly.*

- Please read the following concerning balancing the brake bias on 4 wheel disc vehicles.

•OE Style or Single Mount Race Pedal with Tandem Outlet Master Cylinder:

Front to rear caliper piston sizes, rotor diameters, and pad compounds must be initially configured to provide the correct range of vehicle bias when using a single bore / tandem outlet master cylinder. If excessive rear brake bias is experienced, an inline adjustable proportioning valve can be used to decrease the rear line pressure to help bring the vehicle into balance. If excessive front brake bias is experienced, first consideration should be given to increasing the rear brake bias to bring the vehicle into overall balance.

•Race Pedal with Dual Master Cylinders and Balance Bar:

Master cylinders must be sized to match the calipers and allow the pedal balance bar to operate near the center of its travel. If it is not possible to fine tune the bias within the adjustable range of the balance bar, then consideration must be given to changing a master cylinder bore size or some other aspect of the brake system to bring the car into balance. Larger bore master cylinders will generate less pressure while decreasing pedal travel. Smaller bores master cylinders will generate higher line pressures with an increase in pedal travel.

- For optimum performance, fill and bleed the new system with Wilwood Hi-Temp[®] 570 grade fluid or EXP 600 Plus. For severe braking or sustained high heat operation, use Wilwood EXP 600 Plus Racing Brake Fluid. Used fluid must be completely flushed from the system to prevent contamination. **NOTE:** *Silicone DOT 5 brake fluid is **NOT** recommended for racing or performance driving.*

- To properly bleed the brake system, begin with the caliper farthest from the master cylinder. Bleed the outboard bleed screw first, then the inboard. Repeat the procedure until all calipers in the system are bled, ending with the caliper closest to the master cylinder. If the caliper is fitted with bleed screws on four corners, make sure the bottom bleed screws are tight. Only bleed from the top bleed screws. **NOTE:** *When using a new master cylinder, it is important to bench bleed the master cylinder first.*

- If the master cylinder is mounted lower than the disc brake calipers, some fluid flowback to the master cylinder reservoir may occur, creating a vacuum effect that retracts the caliper pistons into the housing. This will cause the pedal to go to the floor on the first stroke until it has "pumped up" and moved all the pistons out against the pad again. A Wilwood in-line 2 lb. Residual Pressure Valve installed near the master cylinder will stop the fluid flowback and keep the pedal firm and responsive.

- Test the brake pedal. It should be firm, not spongy, and stop at least 1 inch from the floor under heavy load.
If the brake pedal is spongy, bleed the system again.

If the brake pedal is initially firm, but then sinks to the floor, check the system for leaks. Correct the leaks (if applicable) and then bleed the system again.

If the brake pedal goes to the floor and continued bleeding of the system does not correct the problem, either air may be trapped in the system, or a master cylinder with increased capacity (larger bore diameter) may be required. Wilwood offers various lightweight master cylinders with large fluid displacement capacities (custom fabricated mounting may be required).

- On some models of disc brake spindles there are "ears" where the OEM calipers were mounted that interfere with the assembly of the Wilwood disc brake kit. If "ear" removal is required, remove only what is necessary to clear the new bracket, retaining appropriate mounting bolt holes.

Brake Testing and Pad Bedding

WARNING • DO NOT DRIVE ON UNTESTED BRAKES BRAKES MUST BE TESTED AFTER INSTALLATION OR MAINTENANCE MINIMUM TEST PROCEDURE

- Make sure pedal is firm: Hold firm pressure on pedal for several minutes, it should remain in position without sinking. If pedal sinks toward floor, check system for fluid leaks. DO NOT drive vehicle if pedal does not stay firm or can be pushed to the floor with normal pressure.
- At very low speed (2-5 mph) apply brakes hard several times while turning steering from full left to full right, repeat several times. Remove the wheels and check that components are not touching, rubbing, or leaking.
- Carefully examine all brake components, brake lines, and fittings for leaks and interference.
- Make sure there is no interference with wheels or suspension components.
- Drive vehicle at low speed (15-20 mph) making moderate and hard stops. Brakes should feel normal and positive. Again check for leaks and interference.
- Always test vehicle in a safe place where there is no danger to (or from) other people or vehicles.
- Always wear seat belts and make use of all safety equipment.

PAD BEDDING PROCEDURE:

• Pump brakes at low speed to assure proper operation. On the race track, or other safe location, make a series of hard stops until some brake fade is experienced. Allow brakes to cool while driving at moderate speed to avoid use of the brakes. This process will properly burnish the brake pads, offering maximum performance.

Associated Components

<u>PART NO.</u>	<u>DESCRIPTION</u>
260-1874	Wilwood Residual Pressure Valve (2 lb for disc brakes)
260-1876	Wilwood Residual Pressure Valve (10 lb for drum brakes)
260-8419	Wilwood Proportioning Valve
290-0632	Wilwood Racing Brake Fluid (Hi-Temp° 570) (12 oz)
290-6209	Wilwood Racing Brake Fluid (EXP 600 Plus) (16.9 oz)
340-1285	Wilwood Floor Mount Brake Pedal (with balance bar)
340-1287	Wilwood Swing Mount Brake Pedal (with balance bar)
260-6764	Wilwood 3/4 inch High Volume Aluminum Master Cylinder
260-6765	Wilwood 7/8 inch High Volume Aluminum Master Cylinder
260-6766	Wilwood 1 inch High Volume Aluminum Master Cylinder
260-8555	Wilwood 1 inch Aluminum Tandem Chamber Master Cylinder
260-8556	Wilwood 1-1/8 inch Aluminum Tandem Chamber Master Cylinder
270-2016	Quick Release Steering Hub (3/4 inch shaft)
270-2017	Quick Release Steering Hub (5/8 inch shaft)
220-3509	Fitting, Straight (1/8-27 NPT to -3)
220-6412	Fitting, 45° Elbow (1/8-27 NPT to -3)
220-6413	Fitting, Adaptor Tubing (10mm to -3)
220-6415	Fitting, 90° Elbow (1/8-27 NPT to -3)