

Rear Coil Spring Kit

1/2 Ton Tahoe/Suburban/Yukon/Avalanche 4wd | 00-06

Part #: 021608

Rev. 040116

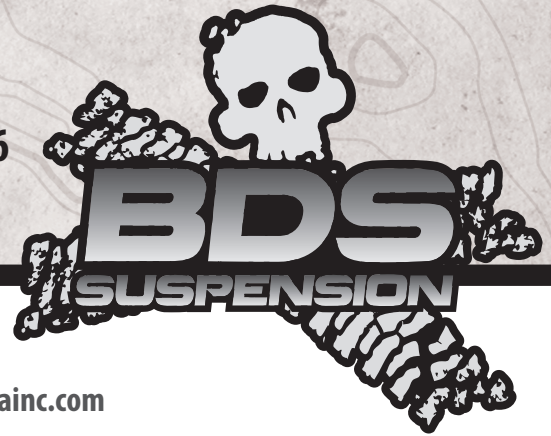

491 W. Garfield Ave., Coldwater, MI 49036 • Phone: 517-279-2135

Web/live chat: www.bds-suspension.com • E-mail: tech-bds@sporttruckusainc.com

SAFETY WARNING

BDS Suspension Co. recommends this system be installed by a professional technician. In addition to these instructions, professional knowledge of disassembly/ reassembly procedures and post installation checks must be known.

INSTALLATION INSTRUCTIONS

1. Block the front wheels for safety.
2. Disconnect the track bar from the rear axle mount. Retain mounting hardware.
3. Raise the rear of the vehicle and support with jack stands under the frame rails just ahead of the lower control arm mounts.
4. Support the axle with a hydraulic jack.
5. Remove the wheels.
6. Remove the OE shocks and sway bar links. Retain all mounting hardware.
7. Disconnect the brake line junction block from the bracket mounted to the differential (Fig 1).

FIGURE 1

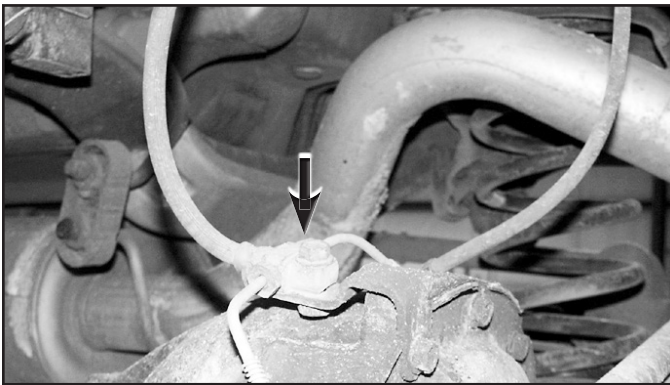

8. Disconnect the parking brake cable loop from the driver's side axle lower control arm mount (Fig 2).

Box Kit 021608		
Part #	Qty	Description
031608	2	Coil Spring
550	1	Bolt Pack
551	1	Bolt Pack
02103	1	Track Bar Bracket
8-1	1	0.875 x 0.134 x 1.670 Spacer Sleeve
02104	2	Bump Stop Extension
911103	2	Sway Bar Link
SB58RB	4	Sway Bar Link Bushing
54314	4	0.625 x 0.060 x 1.475 Sleeve
37-1	1	Brake Line Spacer
	3	Zip Tie
	2	1/2"-13 x 1-1/4" bolt grade 8 yellow zinc
	1	9/16"-12 x 3-1/2" bolt grade 8 yellow zinc
	4	1/2" SAE flat washer yellow zinc
	2	9/16" SAE flat washer yellow zinc
	2	1/2"-13 prevailing torque nut yellow zinc
	1	9/16" - 12 prevailing torque nut yellow zinc
	4	7/16"-14 x 1" bolt grade 5 clear zinc
	4	7/16"-14 prevailing torque nut clear zinc
	8	7/16" SAE flat washer clear zinc
	2	12mm-1.75 x 70mm bolt class 10.9 clear zinc
	2	12mm-1.75 prevailing torque nut clear zinc
	4	7/16" USS flat washer clear zinc
	1	8mm-1.25 x 100mm bolt class 8.8 clear zinc
	1	5/16" SAE flat washer thru-hardened yellow zinc
	1	Cable Clamp

FIGURE 2

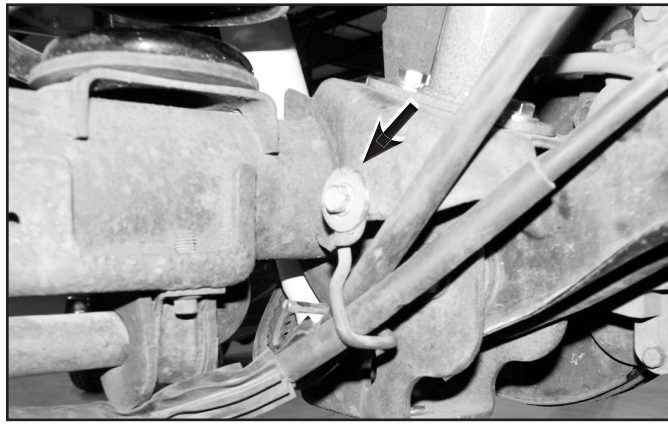

9. Disconnect the parking brake cable loop from the passenger's side frame rail. Remove the loop from the cable (Fig 3).

FIGURE 3

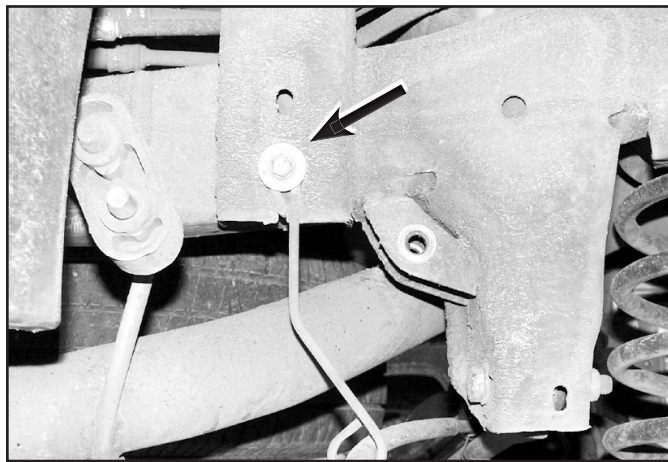

10. Remove the parking bracket cable from the retaining clips holding it to the rear track bar (Fig 1).
11. Loosen but do not remove the four (two per arm) lower control arm pivot bolts.
12. Lower the rear axle until the springs can be pulled free. Remove the springs. Retain the top and bottom rubber isolators. Note: Take care not to over-extend the brake lines.
13. Ensure that the axle is well supported and remove the lower control arm-to-axle pivot bolts and swing the lower control arms down away from the axle.
14. Mark and cut the small tab protruding out on the top front end of the lower control arm mounts so that a single straight edge is left (Fig 4).

FIGURE 4

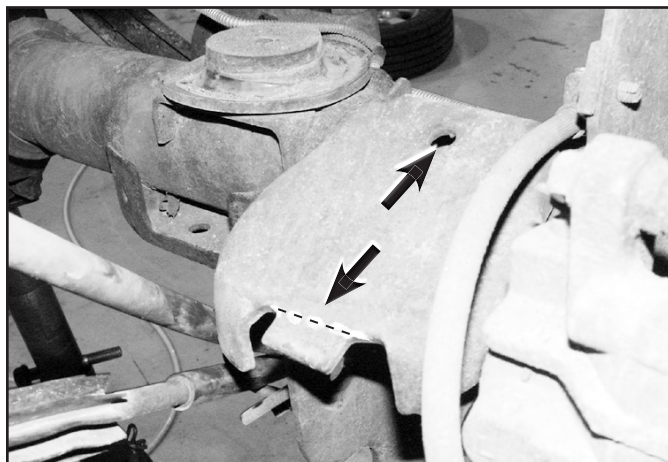

- Loosely mount the provided bump stop brackets on the top of the lower control arm axle mount using the existing hole (Fig. 4) and 7/16" hardware from bolt pack #551. The longer end of the mounting plate will go to the front of the vehicle (Fig 5).

FIGURE 5

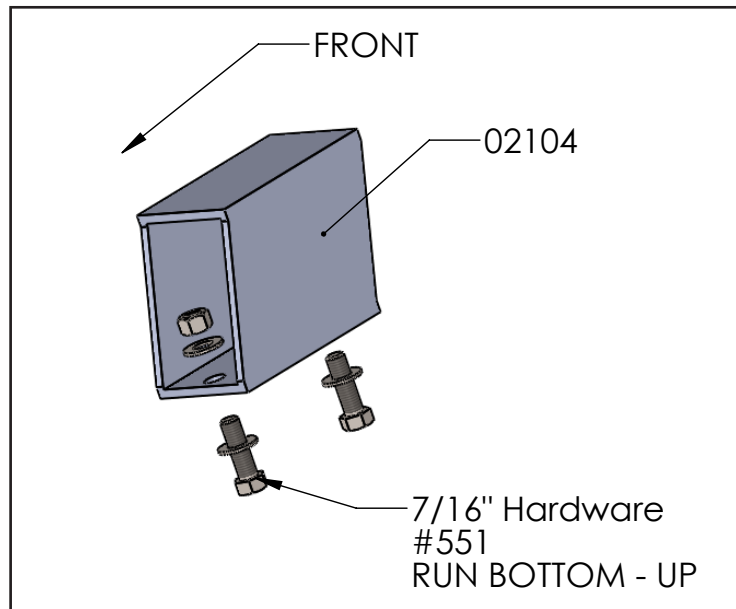

- With the bump stop brackets in position, using the bracket as a template, mark the other mounting hole to be drilled in the axle mount.
- Rotate the brackets out of the way and drill 7/16" holes at the marks. Attach the brackets with the remaining 7/16" hardware and torque all four mounting bolts to 50 ft-lbs.
- Install the new coil spring in conjunction with the OE upper and lower rubber isolators. Note: Take care not to over-extend the brake lines.
- Raise the axle to engage the springs enough to allow for the lower control arms to be reattached. Reattach the lower control arms with the OE hardware. Leave hardware loose.
- Loosely install the provided track bar relocation bracket to the axle with a 9/16" x 3-1/2" bolt, nut and 9/16" SAE washers from bolt pack #550 through the original track bar mounting hole (Fig 6).

FIGURE 6

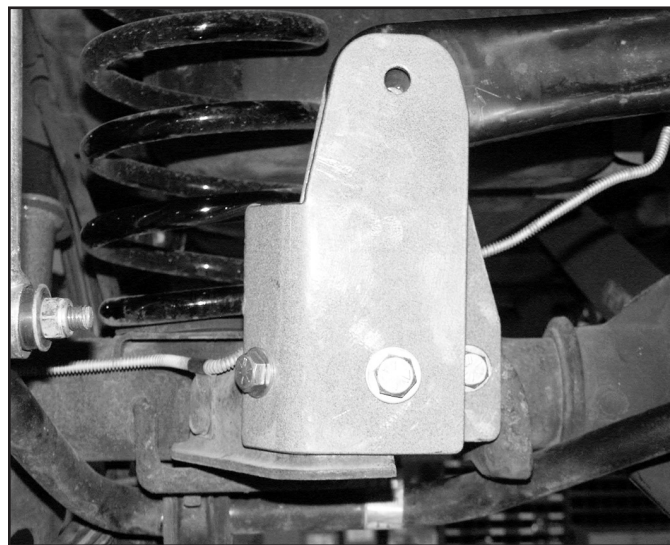

- Ensure that the track bar bracket is square to the bottom of the OE bracket and mark the remaining two holes in the bracket to be drilled. Remove the bracket and drill 1/2" holes at the two marks.
- Reinstall the track bar bracket with the 9/16" hardware in conjunction with the provided 7/8" spacer sleeve (Fig 7). Leave loose.

FIGURE 7

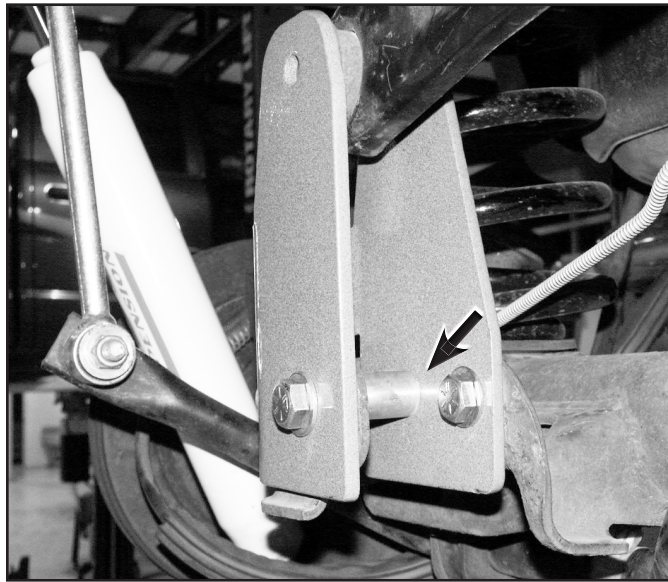

23. Attach the bracket through the two drilled holes with $\frac{1}{2}$ " x 1-1/4" bolts, nuts and $\frac{1}{2}$ " SAE flat washers. Leave loose.
24. Tighten the track bar bracket hardware starting with the 9/16" (95 ft-lbs) and then the $\frac{1}{2}$ " (65 ft-lbs). The track bar will be reinstalled later with the weight of the vehicle on the axle.
25. Install the provided bushings (SB58) and sleeves (54314) in the new extended sway bar links. Install the links with the OE upper hardware and the provided 12mm x 70mm bolts, nuts and 7/16" USS flat washers from bolt pack #551 at the sway bar (Fig 8). Torque hardware to 60 ft-lbs.

FIGURE 8

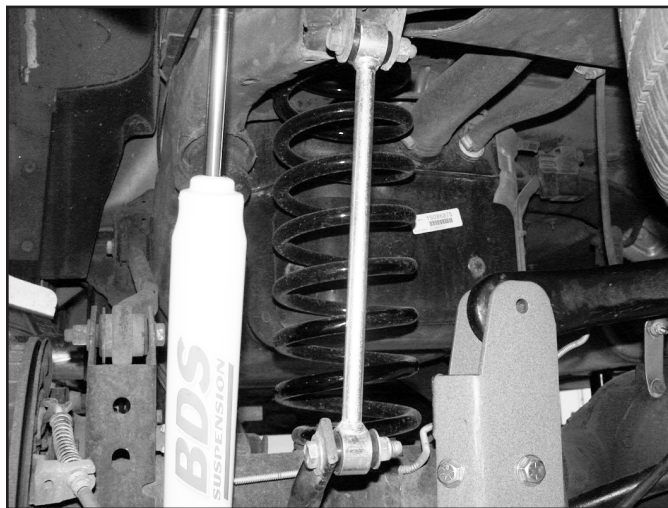

26. Install the new shocks with the OE hardware. Use two provided large shim washers at each shock mount. Torque to 90 ft-lbs.
27. Install the provided brake line spacer sleeve (37-1) between the brake line junction block and the differential mounting tab and fasten with the provided 8mm x 100mm bolt and 5/16" washer from bolt pack #551 (Fig 9). Torque to 15 ft-lbs.

FIGURE 9



28. Reattach the parking brake cable to the driver's side axle mount with the original hardware.
29. Remove the brake line bracket mounting bolt at the differential (Fig 10). Attach the parking brake cable to the differential using the bracket mounting bolt through the provided cable clamp. Torque to 20 ft-lbs. Ensure that the cable is routed so that it does not rub on any suspension components. Use the provided plastic wire ties where necessary.

FIGURE 10



30. Install wheels and lower vehicle to ground. Bounce the vehicle to settle the suspension.
31. Torque the lower control arm mounting bolts to 95 ft-lbs.
32. Install the track bar in the track bar relocation bracket with the OE hardware. Torque to 90 ft-lbs.
33. Check all hardware for proper torque.
34. Check all hardware after 500 miles.