



Part # 12297250 - 2015-Up Ford F150 Traction Bar

Recommended Tools



**2015-Up Ford F150 Traction Bar
Installation Instructions**

Table of contents

- Page 2..... Included Components
- Page 3..... Hardware List & Getting Started
- Page 4-5..... Traction Bar Installation
- Page 6..... Final Tightening & Adjustment

THIS KIT IS DESIGNED TO BE USED WITH THE RIDETECH REAR LOWERING KIT.

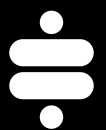



Major ComponentsIn the box

Item #	Part #	Description	QTY
1	90003278	Traction Bar Assembly	2
2	90003281	Traction Bar Pivot Mount	2
3	90003279	Traction Bar Pivot	2
4	99506002	1/2"-13 U-Bolt, 3.25" Wide x 5.50" Long	4
5	90003291	Aluminum Spacer - Heim - .625" ID x .825 L	2
6	90003280	Traction Bar Pivot Inner Sleeve	2
7	70015436	Traction Bar Pivot Delrin Bushing	4
8	90001589	Heim End - 3/4"-16 RH x 5/8" Through Hole	2
9	90001591	Heim End - 3/4"-16 LH x 5/8" Through Hole	2
10	99752004	3/4"-16 RH Jam Nut	2
11	99752006	3/4"-16 LH Jam Nut	2
12	70013322	Traction Bar Pivot Bumpstop	2

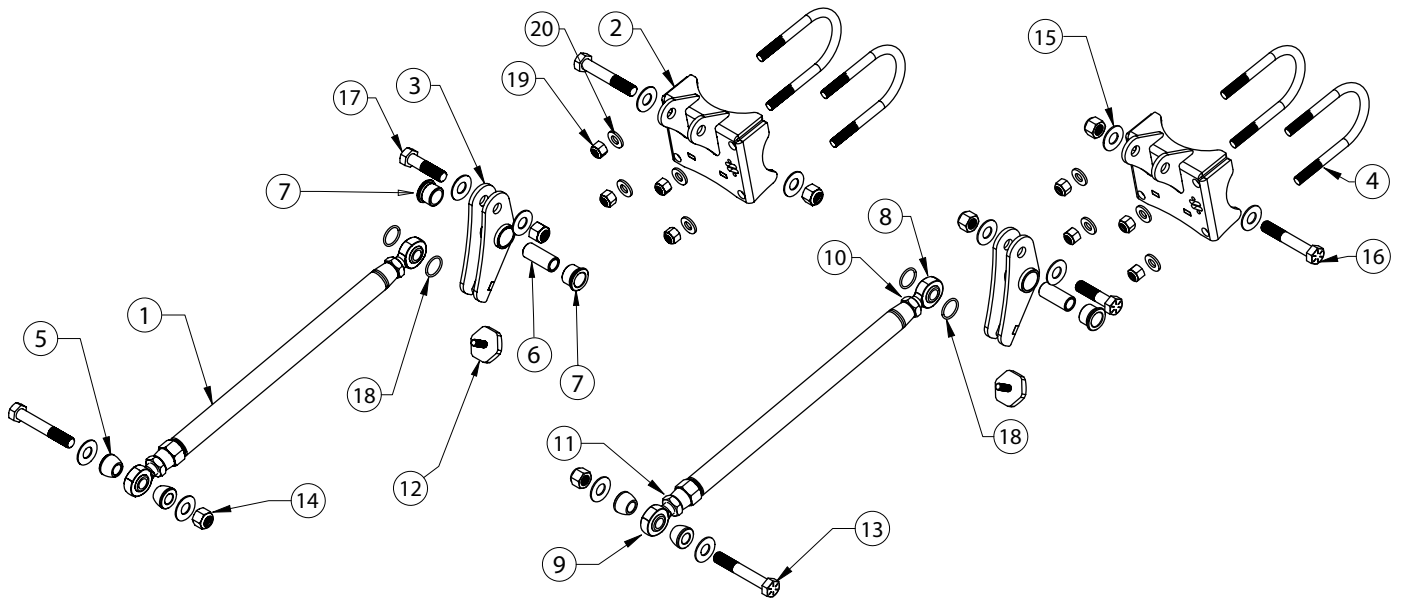



Hardware Kit# 99010170

Item #	Part #	Description	QTY	Item #	Part #	Description	QTY
BAR TO FRONT MOUNT				BAR TO PIVOT			
13	99621010	5/8"-18 x 4" Hex Bolt	2	14	99622001	5/8"-18 Nylok Nut	2
14	99622001	5/8"-18 Nylok Nut	2	15	99623001	5/8" SAE Flat Washer	4
15	99623001	5/8" SAE Flat Washer	4	17	99621022	5/8"-18 x 2 1/2" Hex Bolt	2
PIVOT TO AXLE MOUNT				18	99007121	#121 O-Ring	4
14	99622001	5/8"-18 Nylok Nut	2	U-BOLTS			
15	99623001	5/8" SAE Flat Washer	4	19	99502009	1/2"-13 X Nylok Nut	8
16	99621006	5/8"-18 x 3 3/4" Hex Bolt	2	20	99503014	1/2" SAE Flat Washer	8
				BAR ASSEMBLY			
				NA	90002276	Anti-Seize	1

Getting Started.....

This traction bar kit utilizes delrin bushings in the pivot. The delrin bushings allow the pivots to move freely and quietly. The delrin is self-lubricating, no lubrication is required.

THE RIDETECH REAR LOWERING KIT NEEDS TO BE INSTALLED BEFORE THE TRACTION BARS CAN BE INSTALLED.

1. Jack the vehicle up to a safe working height and support with jack stands. Make sure the jack stands are stable before working under the truck.

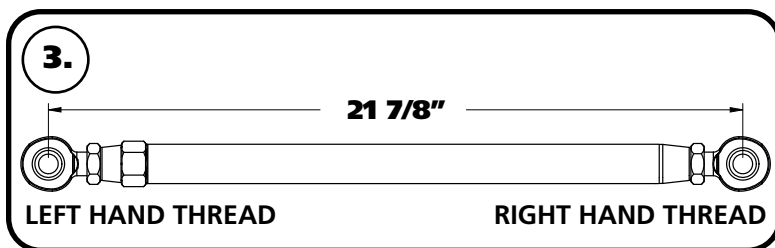

3. Apply anti-seize to the threads of the Heim ends and assemble each traction bar. Set to 21 7/8" center to center. Each bar has Right Hand and Left Hand Threads. The LH threads are on the end with the hex. The kit includes (2) RH thread heims & 2 LH thread heims along with jam nuts for each. Snug the nuts by hand, but do not tighten until the bars have been adjusted.

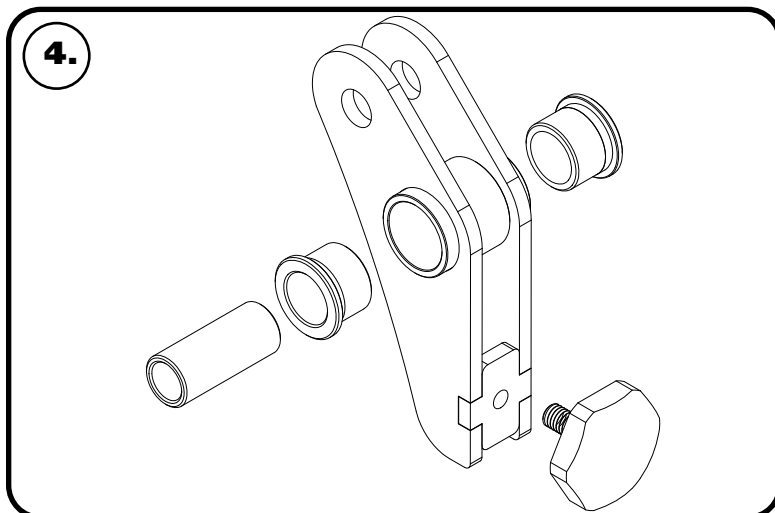

4. Assemble the pivot by pushing in the delrin bushings and inner sleeve. Next, thread the bumpstop into the pivot.



Traction Bar Installation



5. Slip the u-bolts over the axle with the threads pointed forward. They will locate on the outsides of the leaf spring u-bolts. Next, slip a traction bar mount over the u-bolts with the pivot mount at the top.



6. Install a 1/2" flat washer & 1/2"-13 nylok nut on the threads of the u-bolts. Snug the hardware down to eliminate any play in the hardware, but leave loose enough to rotate the mount on the axle tube. Rotate the mount upward until it stops against the leaf spring pad. Torque the nuts to 55 ft-lbs in a criss-cross fashion. Repeat on the other side.



7. Install a supplied o-ring on each side of the rod end that will slip into the rear pivot. Hold the o-rings in place as you insert the rod end into the pivot.



Traction Bar Installation



8. Align the mounting holes with the through hole of the rod end. Install a 5/8" flat washer on a 5/8"-18 x 2 1/2" bolt. Insert the bolt/washer through the aligned holes. Assemble both bars & pivots.



9. Install a 5/8" flat washer and 5/8"-18 nylok nut on the threads of the bolt. Torque to 115 ft-lbs. Repeat for the other side.



10. Insert the pivot/bar into the axle mount. The pivot needs to be installed with the bar at the top and the bumpstop to the axle mount. Install a 5/8" flat washer on a 5/8"-18 x 3 3/4" bolt. With the mounting holes aligned with the pivot inner sleeve, insert the bolt/washer. Install a 5/8" flat washer & 5/8"-18 nylok nut on the bolt. Torque to 115 ft-lbs.



Traction Bar Installation



11. The front heim requires a .825" spacer on each side of the heim to position it in the front bracket. Install a 5/8" flat washer on a 5/8"-18 x 4" bolt. Start the bolt/washer in the outer tab of the front mount. Install a spacer on the bolt sticking through the outer tab. Slip the bolt into the heim and insert the 2nd spacer on the other side of the heim. Push the bolt all the way in and install a 5/8" flat washer and 5/8"-18 nylok nut. Torque to 115 ft-lbs.

Final Tightening & Adjustment

12. SET THE TRUCK ON THE GROUND TO CHECK THE ADJUSTMENT OF THE TRACTION BARS!

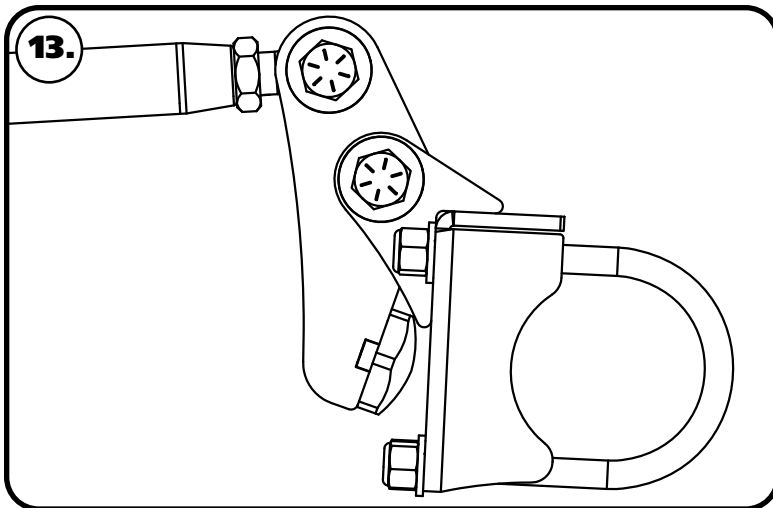

13. WITH THE TRUCK ON THE GROUND, THE SET LENGTH OF THE BARS NEED TO BE CHECKED. The bars need to be set so there is approximately 1/8" gap between the bumpstop and axle mount. Adjust the traction bar to get this gap set. After you check the gap, tighten the jam nuts on the traction bar to 65 ft-lbs using a crows foot on a torque wrench.