

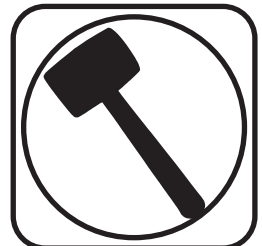

Part # 12270201 - 2015 Up Mustang HQ CoilOver Kit

Front Components 12273210	Front CoilOver Kit
Rear Components 12276210	Rear CoilOver Kit

Recommended Tools

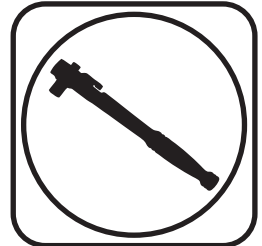

**2015 Up Mustang HQ Series Coil Overs
Installation Instructions**

Table of contents

Page 2-11.....	Front Installation Instructions
Page 12-20.....	Rear Installation Instructions
Page 21.....	CoilSpring Adjustment
Page 22-23.....	Shock Tuning



Part # 12273210 - 2015 Up Mustang HQ CoilOver



Recommended Tools

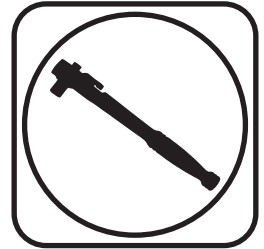

2015 Up Mustang Front HQ CoilOver Strut Installation Instructions

Table of contents

Page 3.....	Included Components
Page 4.....	Disassembly and Getting Started
Page 5-11.....	Strut Installation
Page 11.....	Final Assembly





Included ComponentsIn the box

Item #	Part #	Description	QTY
1	986-10-055	Strut Cartridge	2
2	90003585	Caster/Camber Guide Plate - Driver	1
3	90003586	Caster/Camber Guide Plate - Passenger	1
4	90003587	Caster/Camber Bolt Plate	2
5	90003588	Caster/Camber Bearing Plate - Driver	1
6	90003589	Caster/Camber Bearing Plate - Passenger	1
7	90003590	Strut Isolator Retaining Cup	2
8	70016907	Strut Isolator	2
9	90001042	Upper Mount Bearing	2
10	90000805	Upper Bearing Snap Ring	2
11	90003591	Front Sway Bar Mount	2
12	90003592	Lower Strut Mount	2
13	90003593	Lower Strut Slug	4
14	038-01-035	Strut Mount Retaining Ring	2
15	210-35-120-0	Rebound Dampening Adjustment Knob	2
16	59080300	8" 300lb Coil Spring	2
17	70010828	Delrin Washer	4
18	70010987	Thrust Bearing	2
19	70010988	Thrust Bearing Washer	4
20	90002070	Coil Spring Cap	2
21	90002365	Coil Spring to Bearing Adapter	2
22	90002368	Upper Bearing to Thrust Bearing Adapter	2
23	90009969	Adjustment Knob Screw - 4-40 x 1/4"	2
24	038-01-006-A	Upper Coil Spring Cap Retaining Ring	2
25	234-15-200	Coil Spring Adjuster Nut	2
26	99050001	Adjuster Nut Locking Screw	2
27	99562003	9/16" -18 Nylok Nut	2
28	72000008	1/4"-20 x 3/4" Flat SHCS	8
29	99371029	3/8" -16 x 3/4" Button HCS	2
30	99371054	3/8" -16 x 7/8" SHCS	4
31	70015872	Spacer	2
	99373002	3/8" SAE Flat Washer	8
	99372001	3/8" -16 Nylok Nut	8

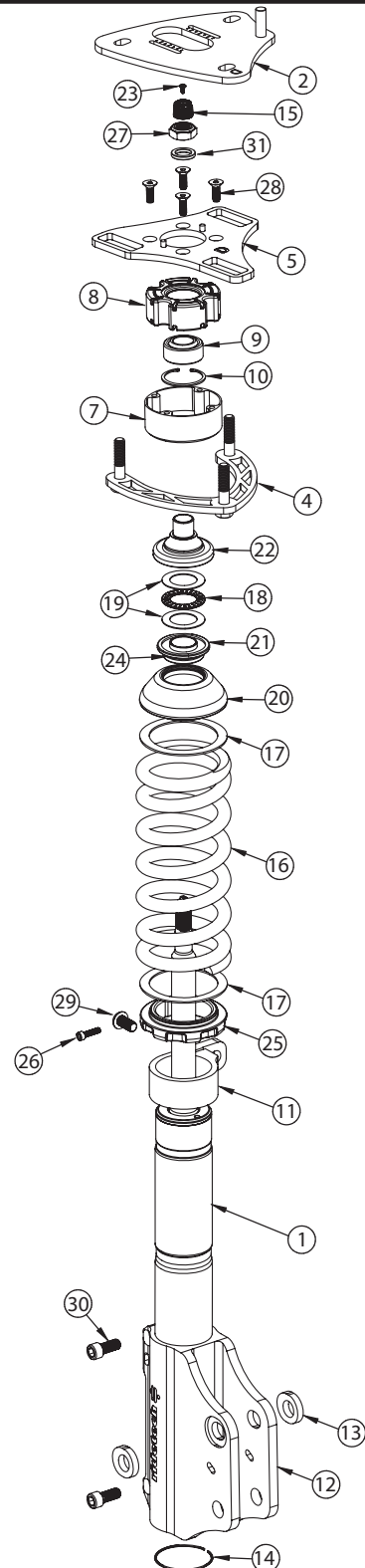



NOTE



DUE TO VARIATIONS IN WIDTH OF THE OEM SWAY BAR, IT MAY BE NECESSARY TO CHANGE THE FRONT SWAY BAR TO RIDETECH SWAY BAR (12279120) WHEN TRYING TO ACHIEVE ALIGNMENT SETTINGS FOR TRACK PURPOSES. REGARDLESS OF YOUR ALIGNMENT SETTING, WE RECOMMEND CHECKING THE CLEARANCE BETWEEN THE STRUT AND THE OEM SWAY BAR LINKAGE

Disassembly

1. Remove the front struts by first disconnecting the ABS wire from the factory strut.
2. Disconnect the swaybar linkage from the strut.
3. Support the front hub and control arm assembly and remove the (2) struts bolts(retain hardware) that attach the strut to the spindle. Retain the lower strut bolts for reassembly.
4. Remove the (3) nuts holding the upper strut mount to the car body. **DO NOT REMOVE THE CENTER NUT.**
5. Remove strut assembly from the car.

Getting Started

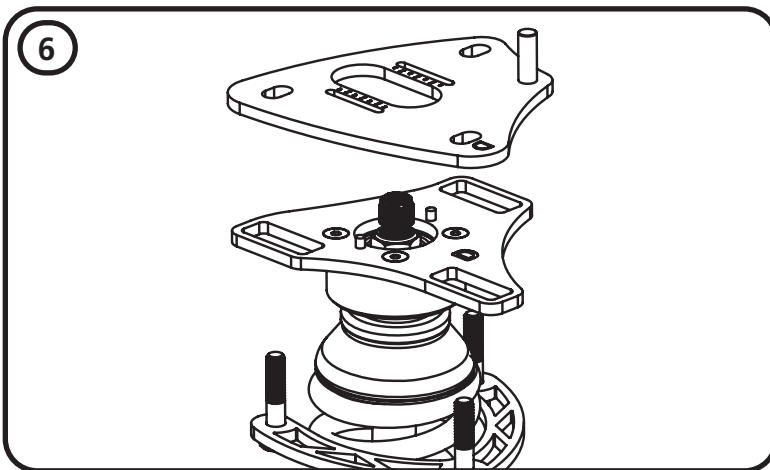

6. The upper strut mount is a 3 piece setup. All 3 pieces will be installed from the bottom side of the strut tower.

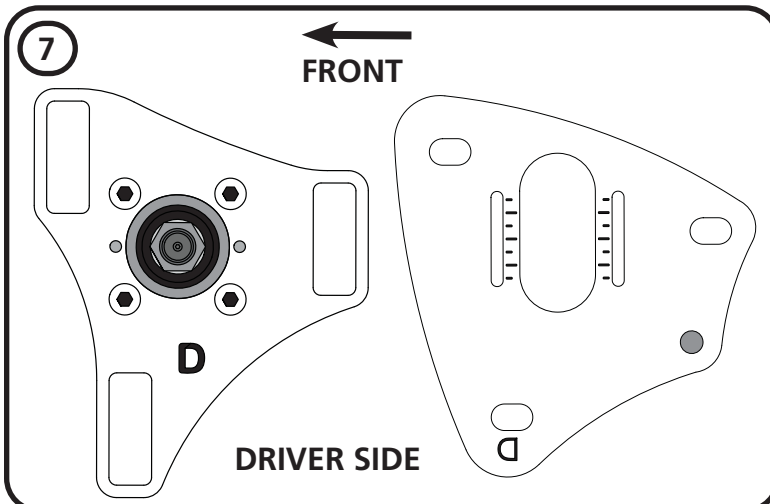

7. The upper mounts are marked with a D and P for Driver and Passenger.



Strut Installation

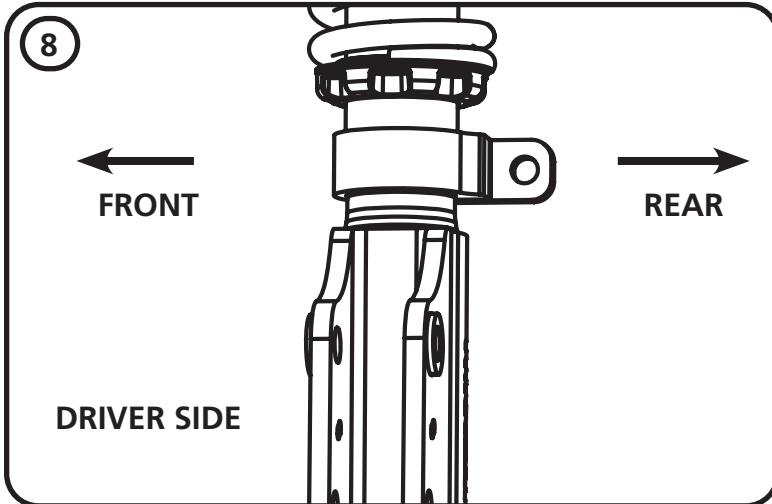

8. There is a driver and passenger strut assembly. The sway bar linkage mounting tab is to the **REAR** of the car. **Image 8** illustrates the Driver Assembly.

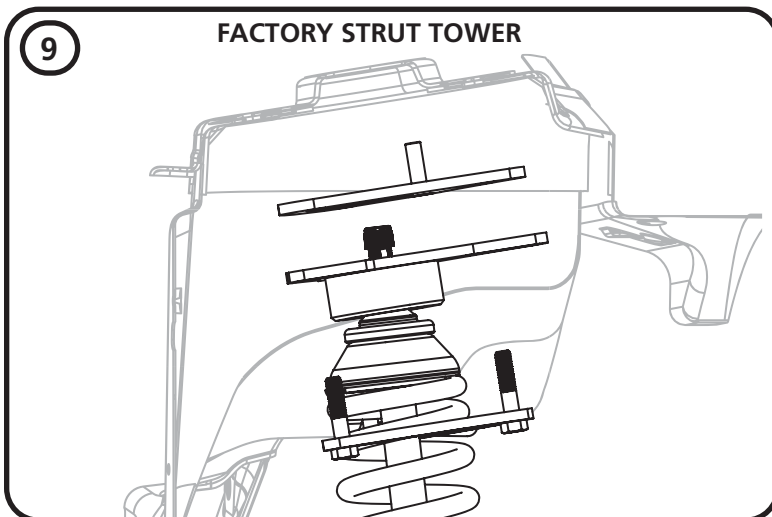

9. **Image 9** illustrates the orientation of the strut mounting components. Installation of these components is covered in **Steps 10-15**.



10. The upper plate has a stud pressed into the plate. The stud will go in the slotted hole that is to the rear of the strut tower. This stud locks down the caster adjustment.

NOTE: If you are only adjusting camber, this nut doesn't need to be loosened.



Strut Installation



11a & 11b. The caster/camber guide plate will sit on top of the bearing plate. The (2) guide pins will get inserted into the slots of the caster/camber guide.



11b. Image 11b illustrates the (2) pins in the slots.



12. The bolt plate will be inserted in from the bottom, with the studs sticking through the slots of the bearing plate & caster/camber plate.



Strut Installation



13. Image 13 shows the bolt plate inserted with the studs sticking through the bearing plate & caster/camber plate.



14. Insert the strut assembly into the car. You will have to hold the bolt plate in place until you can get nuts started on the top. The open end of the bolt plate will be facing the engine.



15. Install a 3/8" flat washer and 3/8"-16 nylok nut on each of the (4) studs. We recommend centering everything in the slots until you can get the front end aligned. Torque the 3/8"-16 nuts to 20 ft-lbs.



Strut Installation



16. Slip the strut mount onto the mounting area of the spindle. Insert the OEM lower strut hardware into the lower hole of the strut mount/knuckle. Install the OEM nut on the bolt.

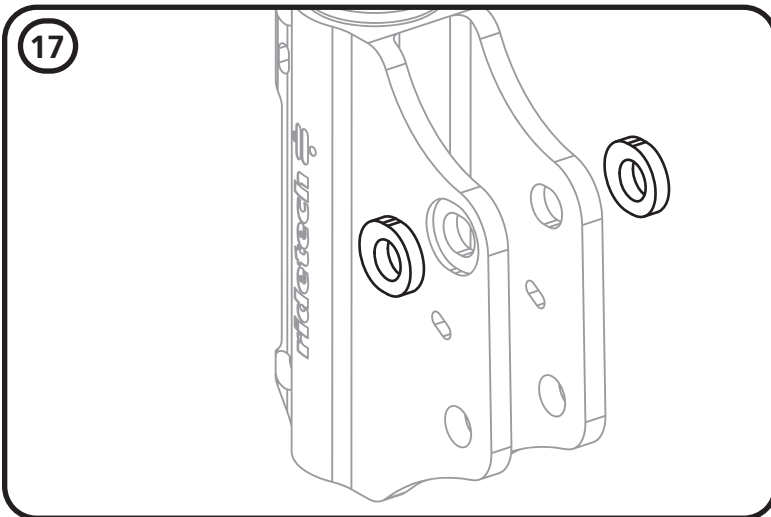

17. The upper strut bolt has a slug setup that allows for a more aggressive alignment settings if you are going to track or auto cross your car. The guide below will help you determine the orientation of the slug for your application.

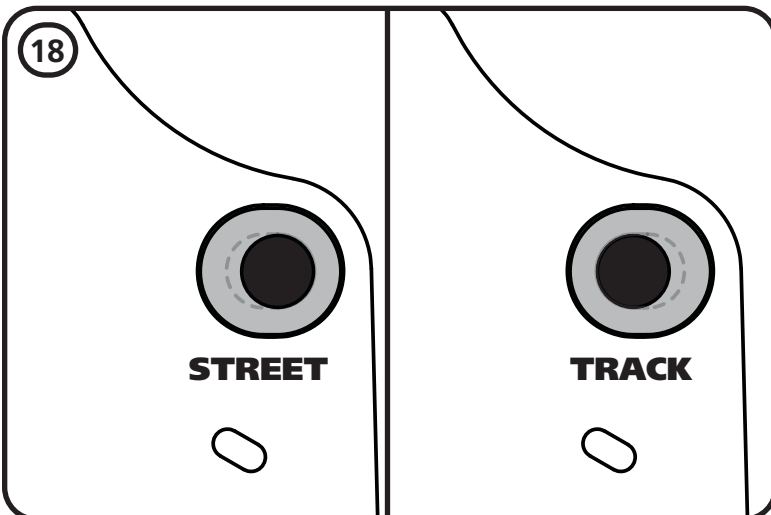

18. The slug can be mounted in 2 different directions. The STREET position has the upper bolt moved outward on the strut mount. The TRACK position has the upper bolt moved inward on the strut mount. **Image 18** illustrates the 2 positions. It is zoomed in to show greater detail. **Image 19** shows the complete lower strut mount with the slugs mounted in the 2 positions.



Strut Installation

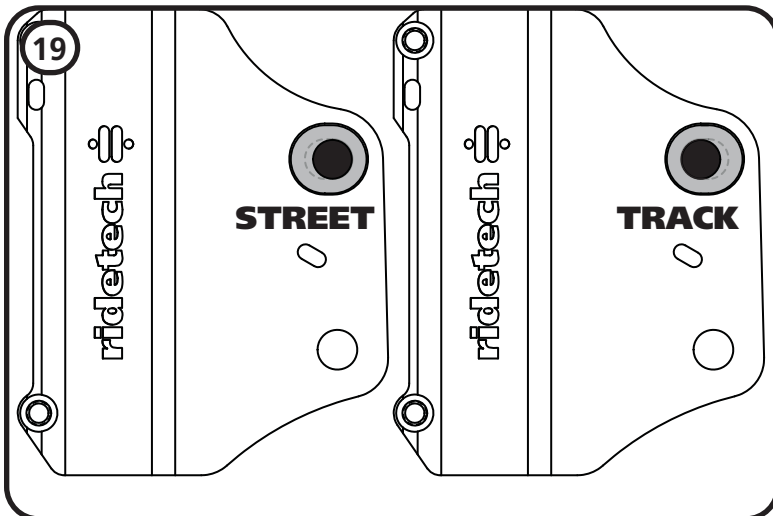

19. Below shows the camber range for each setting.

STREET : +.25° to -2.5°
TRACK : -1.0° to -4.25°

The upper strut mount has a caster range of +7.5° to +8.5°.



20. Insert the slugs into the strut mount using **Steps 18 & 19** as a guide. Make sure the front and rear slugs are orientated in the same direction. Also, make sure the slugs are installed in the same orientation drivers side and passenger side.



21. Insert the OEM lower strut hardware into the upper hole of the strut mount/knuckle.



Strut Installation



22. Install the OEM nut on the bolt.

Torque the strut to steering knuckle hardware to 184 ft-lbs.



23. Attach the sway bar linkage to the strut using the OEM hardware. Torque to 85 ft-lbs.

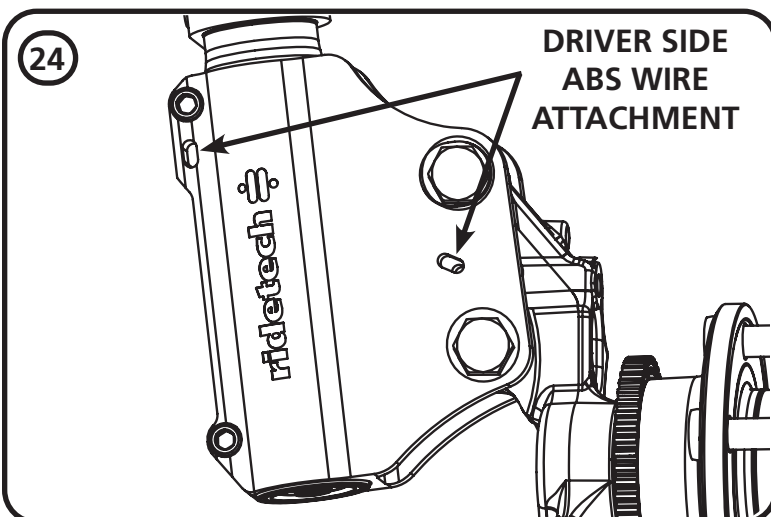

24. The ABS wire attaches to the strut in the locations shown in **Image 24**. The OEM mounting clips are used to attach the ABS wire.



Strut Installation



25. Attach the outer ABS wire mount to the provision in the tab of the strut.



26. Attach the inner ABS wire mount to the provision in the rear flange of the strut.

Final Assembly

27. Repeat steps 11-26 on the Passenger side.

28. With Both sides installed, slowly lower the car to the ground to check ride height. It may be necessary to tighten the Adjusting nut (Also known as preloading the Coil Spring) to achieve proper ride height. To do this you will need to loosen the Adjuster Nut Locking Screw and tighten the Adjuster Nut to put preload into the Coil Spring. Once the correct ride height is achieved tighten the Locking Screw in the lower Adjuster nut. **It may be helpful to read the section pertaining to spring preload and adjustment below.**

IT IS NECESSARY TO HAVE THE CAR ALIGNED AFTER INSTALLATION. TORQUE THE STRUT TO SPINDLE ATTACHING BOLTS TO 184 FT-LBS.



Part # 12276210 - 2015 up Mustang HQ Rear CoilOvers

Recommended Tools

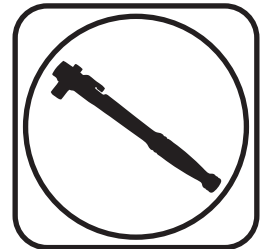

2015 up Mustang HQ Series Rear CoilOvers Installation Instructions

Table of contents

Page 13-14.....	Included Components
Page 14.....	Getting Started and Disassembly
Page 14-16.....	Disassembly
Page 16.....	CoilOver Assembly
Page 17.....	CoilOver Installation
Page 18.....	RivNut Installation
Page 19-20.....	CoilOver Installation continued
Page 21.....	CoilSpring Adjusting
Page 22.....	Shock Tuning





Major ComponentsIn the box

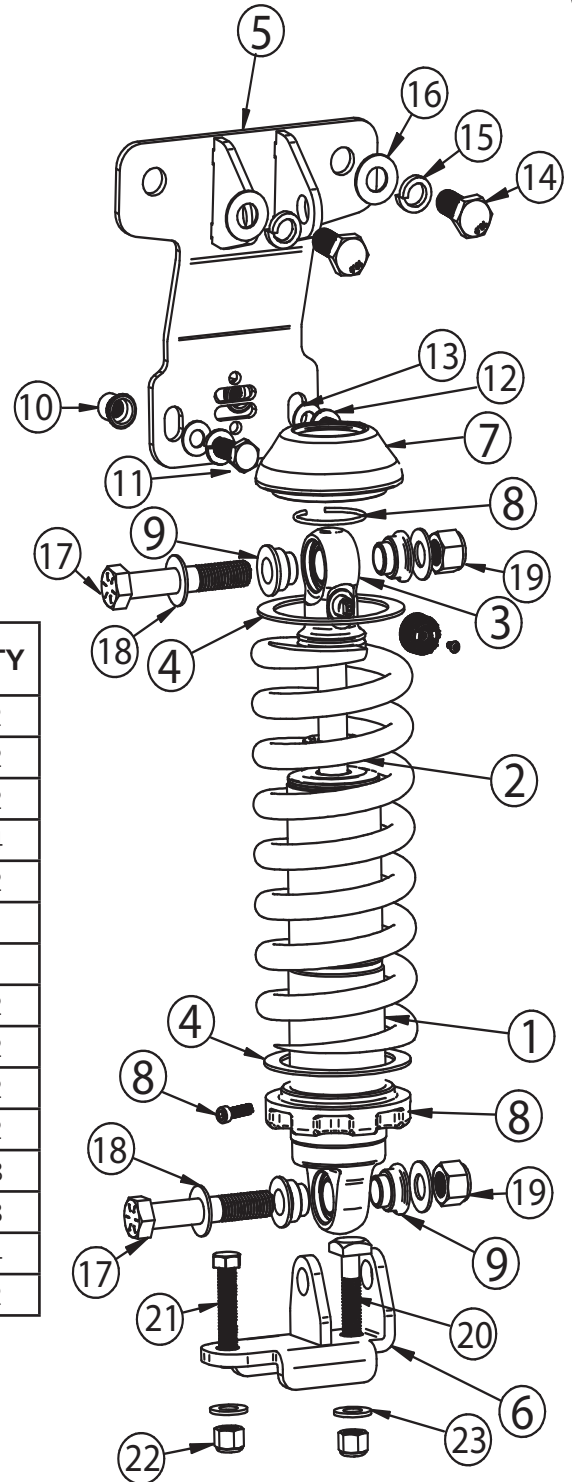

Item	Part #	Description	QTY
1	24149998	4.1" Stroke HQ Series Shock	2
2	59080400	8" 400lb CoilSpring	2
3	90003598	1.7" Eyelet	2
4	70010828	Delrin CoilSpring Washer	4
5	90002481	Upper Shock Mount	2
6	90002482	Lower Shock Mount; Driver	1
6	90002483	Lower Shock Mount; Passenger (Not Shown)	1
7	90002070	Dropped Upper CoilSpring Mount	2
8	038-01-006-A	CoilSpring Retaining Ring	2
8	234-15-200	Lower Spring Adjuster Nut	2
8	99050001	Adjuster Nut Locking Screw	2
9	90002043	Shock Spacer	8
	90001995	Bearing Snap Ring (Installed in Shock Body)	8
	90001994	5/8" ID Bearing (Installed in Shock Body)	4
	70012266	Sway Bar Relocator (Not Shown)	2



HARDWARE LIST - Kit # 99010247

Item #	Part #	Description	QTY	Item #	Part #	Description	QTY
UPPER BRACKET TO CAR				LOWER MOUNT TO CONTROL ARM			
10	99372007	3/8"-16 Riv-Nut	5	20	99371048	3/8"-16 x 2" Square Head Bolt	2
11	99371005	3/8"-16 x 1 1/4" Hex Bolt	4	21	99371077	3/8"-16 x 2" Hex Head Bolt	2
12	99373006	3/8" Lock Washer	4	22	99372001	3/8"-16 Nylok Nut	4
13	99373002	3/8" SAE Flat Washer	4	23	99433005	7/16" SAE Flat Washer	4
14	99121005	M12-1.75 x 30mm Hex Bolt	4	SWAY BAR RELOCATOR			
15	99503015	1/2" Lock Washer	4		99371065	3/8"-16 x 3/4" Hex Bolt	4
16	99503014	1/2" SAE Flat Washer	4		99433002	3/8" SAE Flat Washer	4
SHOCK TO UPPER/LOWER MOUNTS							
17	99501050	1/2"-13 x 2 1/2" Hex Bolt	4				
18	99503014	1/2" Flat Washer	8				
19	99502009	1/2"-13 Nylok Nut	4				

Getting Started and Disassembly

Congratulations on your purchase of the Ridetech Mustang CoilOver System. This system has been designed to give your Mustang excellent handling along with a lifetime of enjoyment. The CoilOver System provides flexibility that can not be achieved with conventional coil springs. The CoilOver System will give you the flexibility of adjusting your ride height along with numerous spring options to dial in your ride quality to your personal preference.

This CoilOver System is designed to replace the factory shock and coil springs.

Refer to the Factory Service Manual for disassembly and coil spring removal instructions.

1. Remove the shocks and the OEM upper shock mount from the car.

This kit utilizes Riv-nut on the upper CoilOver mount. An Instruction sheet is supplied for the Riv-nut installation. Read the Riv-nut instruction sheet on how to install the Riv-nut. A drill bit and installation tool is supplied with this kit. The upper mount will be used as a guide for drilling the holes.



2. Unbolt the brake line bracket from the chassis. Retain the hardware for reassembly.



Disassembly



3. Detach the ABS wire from the chassis.



4. Remove the ABS wire from the bracket on the knuckle.



5. Disconnect the sway bar linkage from the sway bar. Retain the hardware for reassembly.



Disassembly & CoilOver Assembly



6. Disconnect the sway bar linkage from the lower control arm. Retain the hardware for reassembly.

7. To assemble the CoilOver you need to:

a. Turn Adjuster Knob all the way in (Clockwise) . Remove Screw from center of Adjustment Knob (1) and remove Adjustment Knob (2).

b. Thread Adjuster Nut (3) onto the CoilOver body. Once it is threaded on the shock body, lightly thread in the locking screw (4) into the Adjuster Nut.

c. Install a Delrin Spring Washer (5) onto the Adjuster Nut.

d. Slide the CoilSpring (6) onto the CoilOver.

e. Install another Delrin Spring Washer (7) on top of the CoilSpring.

f. Install the Upper Drop CoilSpring Cap (8) onto the CoilSpring.

g. Install the CoilSpring Retaining Ring (9) onto the Upper Eyelet (10). It fits into the groove in the base.

h. Reinstall Adjuster Knob (2) and Screw (1). Repeat on second CoilOver.

Note: Remember to adjust the shock valving before driving, the shock is currently set to full stiff.

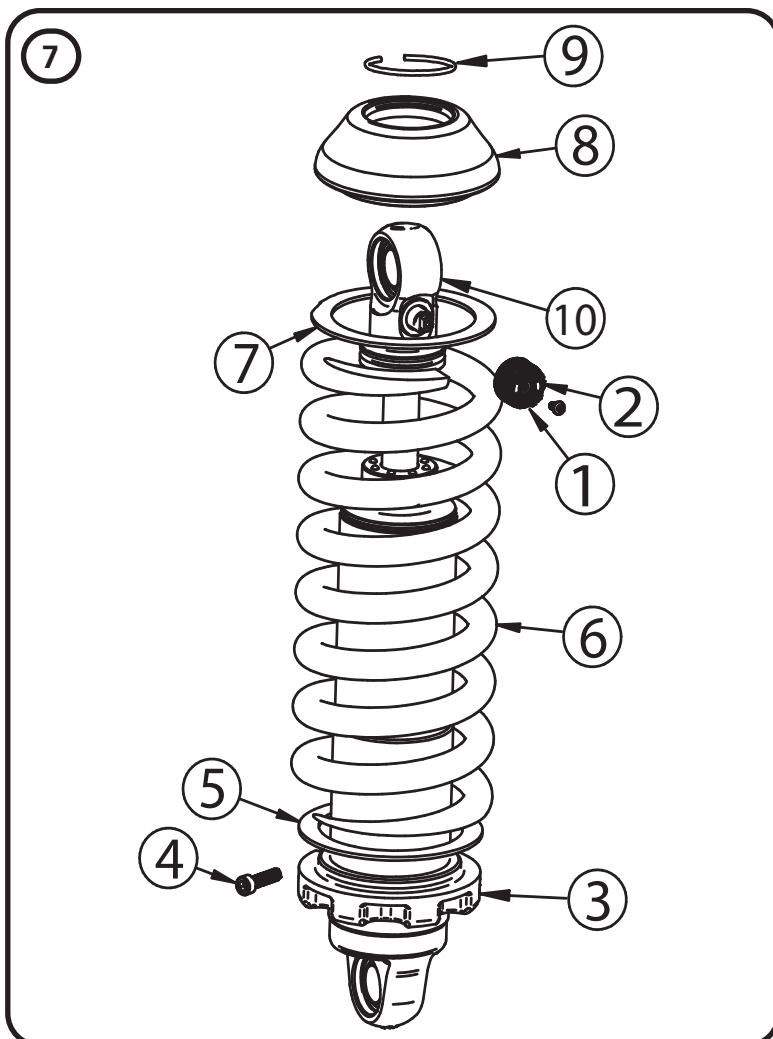



CoilOver Installation

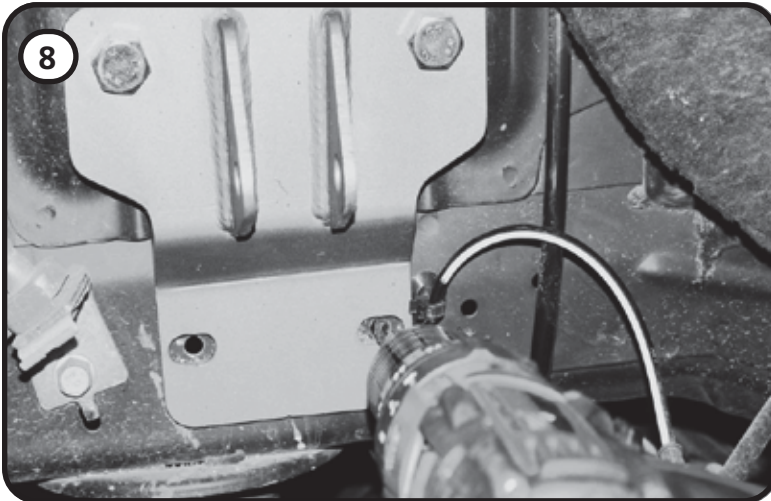

8. Bolt the upper CoilOver mount into the OEM location using (2) M12-1.75 x 30mm hex bolts, (2) 1/2" lock washers, & (2) 1/2" flat washers. Tighten enough to hold in place. Use the shock mount as a guide to mark the center of each slot. After the holes are marked, remove the upper shock mount. A 17/32" drill bit is included in the kit, but we suggest drilling a pilot hole with a smaller bit before using the 17/32" Drill Bit.

Repeat for both sides.

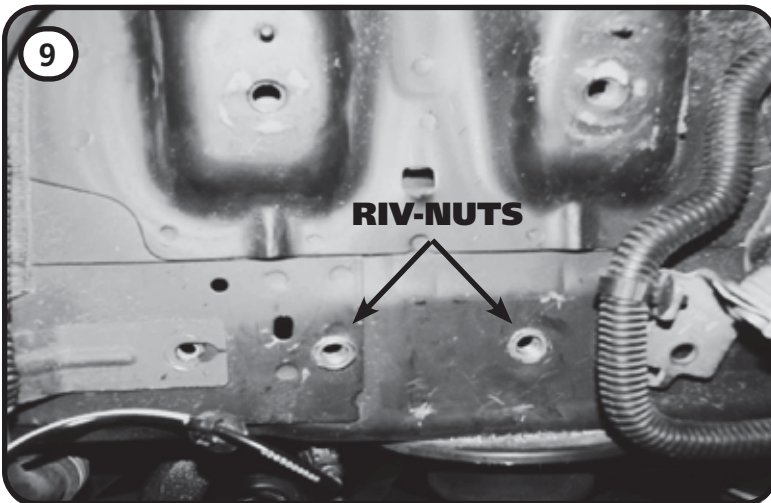

9. Install (2) Riv-nuts using the supplied tool and instructions on **Page 7** for Riv-nut installation. Do this for both sides.

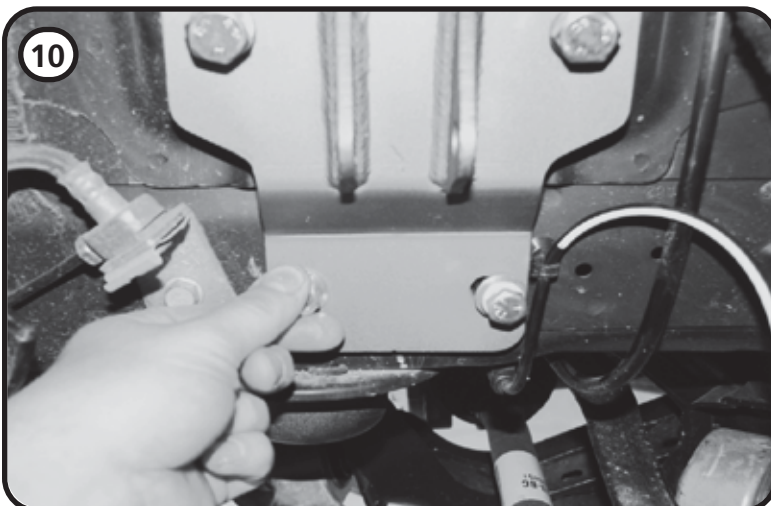

10. Reinstall the upper shock mount as in **Step 8**, adding (2) 3/8"-16 x 1 1/4" hex bolts, (2) 3/8" flat washers, & (2) 3/8" lock washers in the bottom 2 holes. Tighten all hardware.

Torque Specs.

3/8"-16 Bolts - 23 ftlbs.

M12-1.75 - 65 ftlbs.



Rivnut® Installation & Specs

1. Drill Hole in Frame using the SUPPLIED DRILL BIT keeping the Drill square with the metal.
2. Thread a Rivnut® onto the supplied Tool. Thread the Rivnut all the way onto the Tool until it stops.
3. Insert the Tool and Rivnut® into the drilled hole 90° to the Frame Rail.
4. The Tool requires (2) 9/16" Wrenches to use. A Ratchet can be used on the top of the Tool.

KEEP THE TOOL AND RIVNUT 90° TO THE SURFACE WHILE TIGHTENING

5. Put a 9/16" Wrench on the Lower Hex of the tool. Use a Wrench or Ratchet on the Top hex to Tighten.
6. Hold the Wrench in one position and turn the TOP HEX CLOCKWISE to engage the Rivnut®. Keep Turning the TOP WRENCH until you feel a positive stop and you can't turn the TOP WRENCH anymore.
7. Break the Tool loose by turning the TOP HEX counterclockwise and thread the Tool out of the Rivnut®

THE DATA BELOW ILLUSTRATES THE STRENGTH OF THE RIVNUT®

RIVNUT® Fastener Engineering Data

Upset Load (lbs.)		
RIVNUT * Size	Steel	
	Min. Grip	Max. Grip
3/8-16	4965	5325

Fig. 1

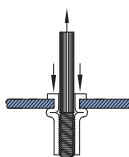

Ultimate thread strength (lbs.)		
RIVNUT * Size	Steel	
	Min. Grip	Max. Grip
3/8-16	11500	10450

Fig.2

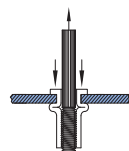

Ultimate tensile strength (lbs.)	
RIVNUT * Size	Steel
3/8-16	3900

Fig. 3

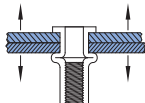

**Single Shear Strength 3/8" Grade 5 Bolt
3,975.8 lbs**

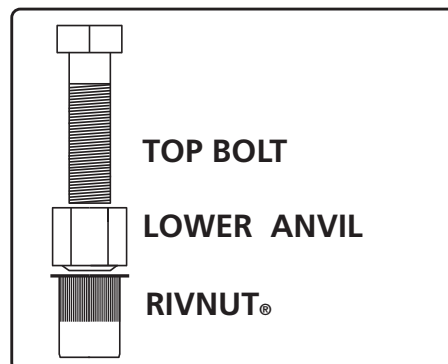

Figure 2

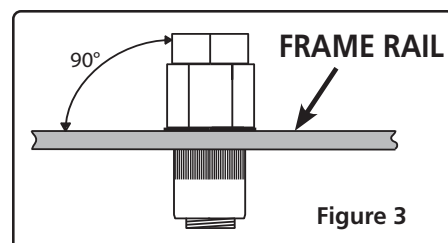

Figure 3

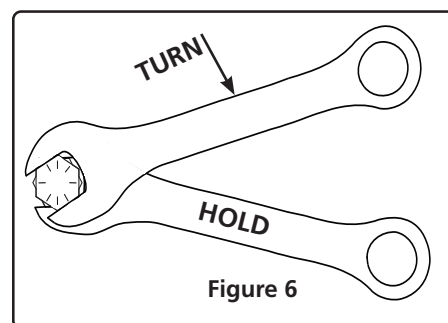
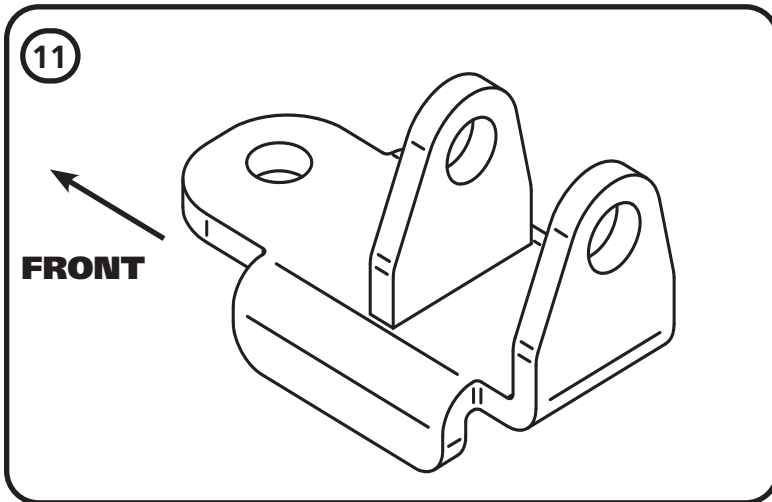

Figure 6



CoilOver Installation continued....

11. Illustration 11 shows the Driver lower shock mount. The shock mount offsets the shock to the rear of the car.



12. Insert (1) 3/8"-16 x 2" square head bolt[2] into the lower shock mount[1] between the 2 shock Tabs. Insert (2) bearing spacers[3] into the bearing in the shock body of the assembled CoilOver. Slide the CoilOver into the lower shock mount, aligning the hole in the mount with the bearing spacers. Slide a 1/2" flat washer[4] onto a 1/2"-13 x 2 1/2" hex bolt[5] and insert the bolt/washer into the lower shock mount/shock. Install a 2nd 1/2" washer[4] followed by a 1/2" nylok. Tighten the lower shock bolt. Insert a 3/18"-16 x 2 hex bolt[7] into the remain hole in the lower shock mount. Repeat for Passenger side. Torque 1/2"-13 x 2 1/2" bolt to 75 ftlbs.

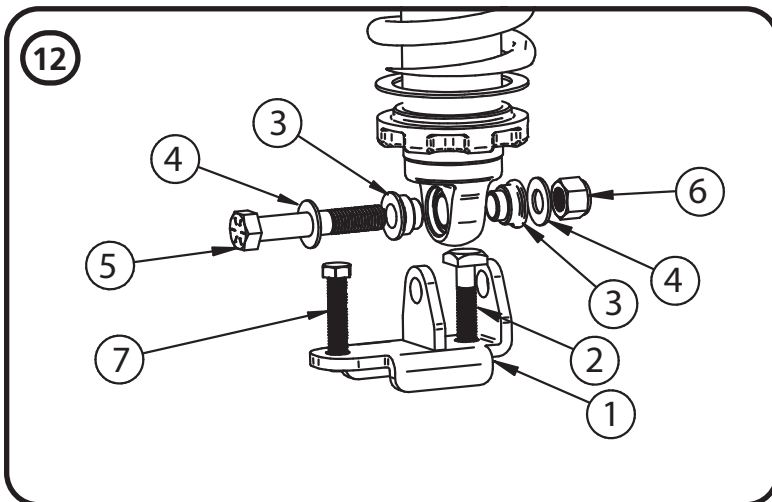

13. Install the CoilOver/lower shock mount assembly on the Driver lower control arm in the OEM shock location. With the assembly in place, insert a 7/16" flat washer on the 3/8"-16 x 2" bolts sticking through the OEM control arm, followed by a 3/8"-16 nylok nut. Torque 3/8" hardware to 23 ft-lbs.

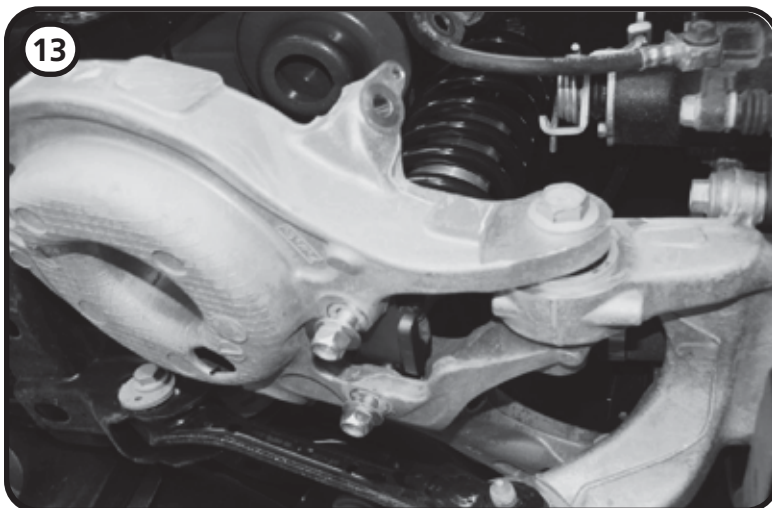

Note: One of the flats on the square head bolt under the CoilOver will lock against the shock tab allowing it to be tightened.



CoilOver Installation continued....

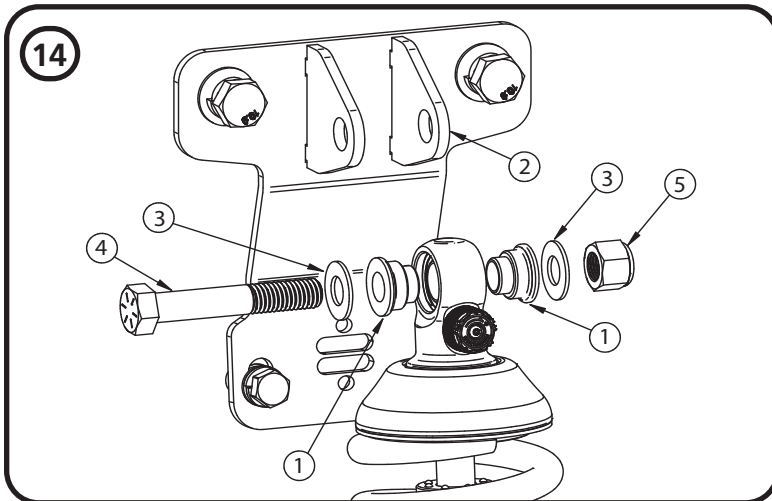

14. Insert bearing spacers[1] into each side of the bearing in the upper CoilOver eyelet. Slide the CoilOver into the upper shock mount[2] aligning the holes in the upper mount with the holes in the bearing spacers. You may have to Jack the lower control arm up to get the holes to align. Install a 1/2" flat washer[3] onto a 1/2"-13 x 2 1/2"" hex bolt[4] and install it through the Shock mount and bearing spacer holes. Install a 1/2" flat washer[3] on the bolt, followed by a 1/2"-13 nylok nut[4]. Torque 1/2"-13 x 2 1/2" bolt to 75 ftlbs.



15. Install the sway bar relocators using the OEM hardware to attach the mount. The bracket should be bolted to the car with the threaded holes to the REAR of the car. Torque the OEM hardware to 52 ft-lbs. Install the sway bar using (4) 3/8"-16 x 3/4" hex bolts and (4) 3/8" flat washers. Torque the 3/8" hardware to 23 ft-lbs.



16. Reinstall the sway bar linkage. Torque the nuts to 85 ft-lbs.

17. Reattach the ABS wires.

18. Reattach the brake line to car body.

Repeat for both sides.



NOTE



DUE TO VARIATIONS IN WIDTH OF THE OEM SWAY BAR, IT MAY BE NECESSARY TO CHANGE THE FRONT SWAY BAR TO RIDETECH SWAY BAR (12279120) WHEN TRYING TO ACHIEVE ALIGNMENT SETTINGS FOR TRACK PURPOSES. REGARDLESS OF YOUR ALIGNMENT SETTING, WE RECOMMEND CHECKING THE CLEARANCE BETWEEN THE STRUT AND THE OEM SWAY BAR LINKAGE

Spring Adjustment and Preload

Start with an initial preload of 1/4". The Locking Screw on the Adjuster Nut has to be loose to Set the Preload. To set this: Screw the Spring Adjuster up snug against the Coil Spring (THIS IS 0 PRELOAD). Measure from bottom of Adjuster Nut to top of the Strut Mount. Using Spanner, Tighten the Adjuster Nut until the measurement from the Nut to the Mount on the Shock is 1/4" greater. Tighten Locking Screw on Adjuster Nut. This will be your starting point for Ride Height. It may be necessary to raise or lower the adjuster to level the car.

Ride Height

We have designed most cars to have a ride height of about 2" lower than factory. To achieve the best ride quality & handling, the shock absorber needs to be at 40-60% overall travel when the car is at ride height. This will ensure that the shock will not bottom out or top out over even the largest bumps. Measuring the shock can be difficult, especially on some front suspensions. Measuring overall wheel travel is just as effective and can be much easier. Most cars will have 4-6" of overall wheel travel. One easy way to determine where you are at in wheel travel is to take a measurement from the fender lip (center of the wheel) to the ground. Then lift the car by the frame until the wheel is just touching the ground, re-measure. This will indicate how far you are from full extension of the shock. A minimum of 1.5" of extension travel (at the wheel) is needed to ensure that the shock does not top out. If you are more than 3" from full extension of the shock then you are in danger of bottoming out the shock absorber.

Adjusting Spring Height

When assembling the CoilOver, screw the spring retainer tight up to the spring (0 preload). After entire weight of car is on the wheels, jounce the suspension and roll the car forward and backward to alleviate suspension bind.

- If the car is too high w/ 0 preload then a smaller rate spring is required. Although threading the spring retainer down would lower the car, this could allow the spring to fall out of its seat when lifting the car by the frame.
- If the car is too low w/ 0 preload, then preload can then be added by threading the spring retainer up to achieve ride height. On 2.6" - 4" stroke shocks, up to 1.5" of preload is acceptable. On 5-7" stroke shocks, up to 2.5" of preload is acceptable. If more preload is needed to achieve ride height a stiffer spring rate is required. Too much preload may lead to coil bind, causing ride quality to suffer.



TUNING GUIDE

SINGLE-ADJUSTABLE SHOCKS



The Basics...

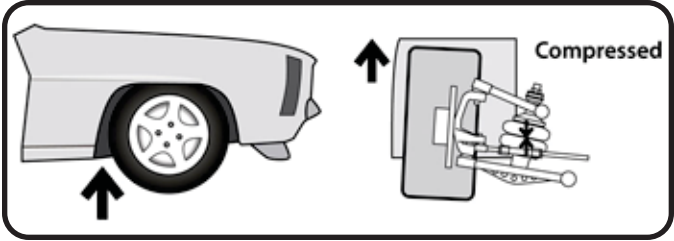

COMPRESSION

This typically occurs when you hit a bump in the road. The bump forces the wheel/tire/suspension assembly to "compress" or move upwards into the car.

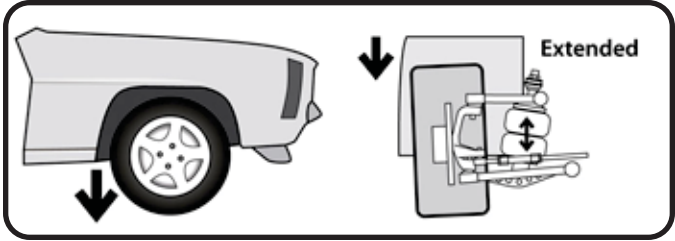

REBOUND

Rebound is the opposite of compression. This occurs when the wheel/tire/suspension assembly falls into a pothole, or simply "rebounds" from being compressed.

Where Are The Knobs?

HQ Series Shocks

- The adjustment knob is located on the top of the shock, either protruding from the side of the eyelet, or atop the stud.
- This knob provides rebound adjustment only.

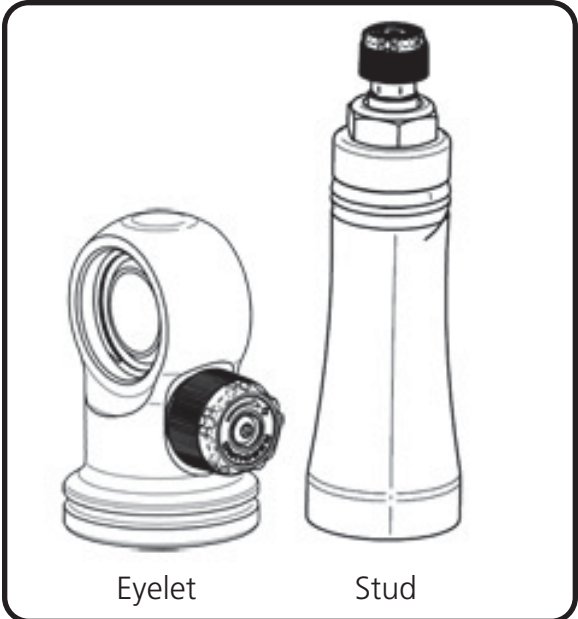

Knob Function

Counterclockwise

=
Softer

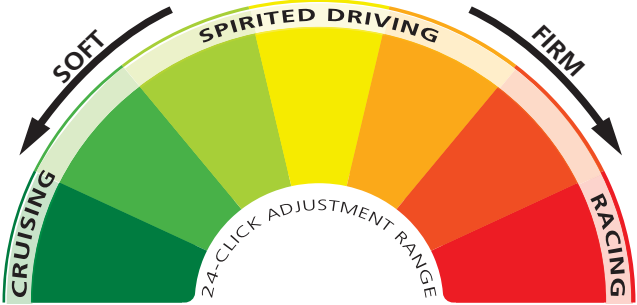

Clockwise

=
Firmer





TUNING GUIDE

SINGLE-ADJUSTABLE SHOCKS



Initial Rebound Setting

NOTE: Before jumping straight to a middle-of-the-road shock setting, we recommend you experience the full range of adjustment potential of your new shocks by first driving your vehicle at both the “full stiff” and “full soft” settings. Understanding how your shocks behave at these extremes will provide recognizable reference points as you attempt to dial in your settings.

1. Begin by setting your shocks to the “full stiff”, or minimal rebound position. You do this by turning the adjustment knob clockwise until it stops.

2. Now turn the adjustment knob counterclockwise 12 clicks. This is the approximate center of the adjustment range.

3. Take the vehicle for a test drive. Try to determine if you are experiencing any of the unwanted behaviors found at the extremes of the adjustment range. If you are satisfied with the ride quality and handling, you’re all set. Enjoy the ride!

4. If the vehicle feels too “floaty” or soft, turn the knob a few clicks clockwise to increase the damping effect.

If the ride quality is still too harsh or stiff, turn the knob a few more clicks counterclockwise to decrease the damping effect.

5. Take the vehicle for another test drive. If necessary, repeat the steps above until your desired optimal ride quality has been achieved.



General Guidelines

- The rear shocks typically have the the most influence on ride quality. This is due to your seating position being closer to the rear than the front.
- Adjustments to the front shocks will generally require 3-4 clicks in any direction to be noticeable, while adjustments to the rear shocks may only require 1-2 clicks to be felt.
- Don't be afraid to turn the knobs and experience the full adjustment range. You are not going to hurt anything and you can always go back if you adjust too far one way or the other.