



350 S. St. Charles St. Jasper, In. 47546
Ph. 812.482.2932 Fax 812.634.6632

www.ridetech.com

Part # 12110201
67-70 Cougar CoilOver System

Front Components:

- 1 12103510 HQ Series Front CoilOvers
- 1 12102899 Lower StrongArms
- 1 12103699 Upper StrongArms
- 1 12109100 Front MuscleBar w/ PosiLinks

Rear Components:

- 1 12106510 HQ Series Rear CoilOvers
- 1 12117199 Bolt-on 4 Link

Components:

- 1 85000000 Spanner Wrench

COILOver

COILOver

ridetech

350 S. St. Charles St. Jasper, In. 47546
Ph. 812.482.2932 Fax 812.634.6632

www.ridetech.com

Part # 12103510

67-70 Mustang/Cougar Front HQ Series CoilOvers

For Use w/ Upper StrongArms

Shock Assembly:

2	24129999	2.6" Stroke HQ Series shock
2	90009988	2" threaded stud top for Adjustable shock
2	90001628	.5" I.D. bearing
4	90001995	bearing snap ring

Components:

2	59080700	Coil spring – 8" long / 700 # rate
2	90002312	2" stud top base
2	90002222	Spring retainer kit (included upper and lower spring retainer, screw & clip)
2	90001902	Aluminum cap for Delrin ball
2	90001903	Delrin ball upper half
2	90001904	Delrin ball lower half
4	70010828	Delrin Spring Washer
2	90002356	Upper Aluminum Shockwave mount
2	90000506	Aluminum Upper plate

Hardware:

2	99562003	9/16" SAE Nylok jam nut	Stud top hardware
6	99311012	5/16" x 1" USS Flange bolts	Upper mount to strut tower

COILOver

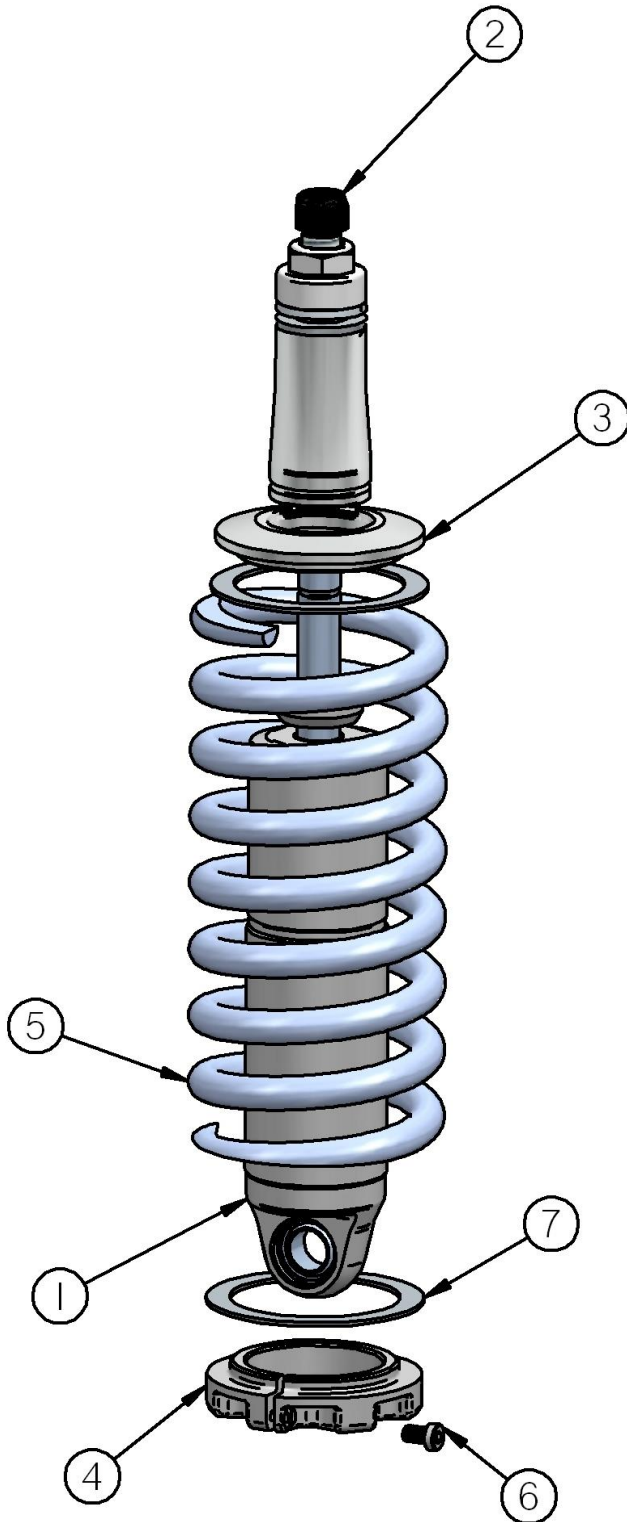

1. Impact Forged, Monotube shock
2. Rebound adjustment knob (SA Only)
3. Upper coil spring retainer
4. Lower coil spring retainer
5. High tensile coil spring
6. Set screw
7. Delrin Spring Washer

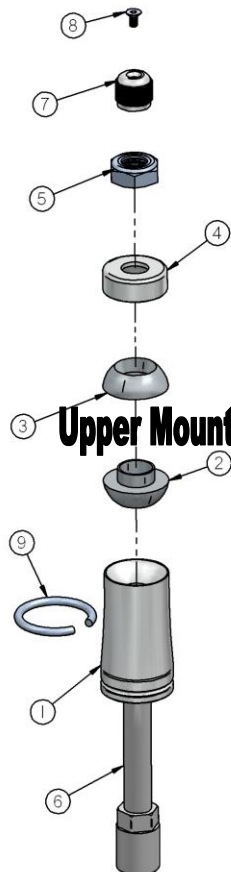

1. Stud top base
2. Lower Delrin ball half
3. Upper Delrin ball half
4. Aluminum cap
5. 9/16" Nylok jam nut
6. Threaded stud
7. Adjustment knob (SA Only)
8. Screw
9. Snap ring

COILOver

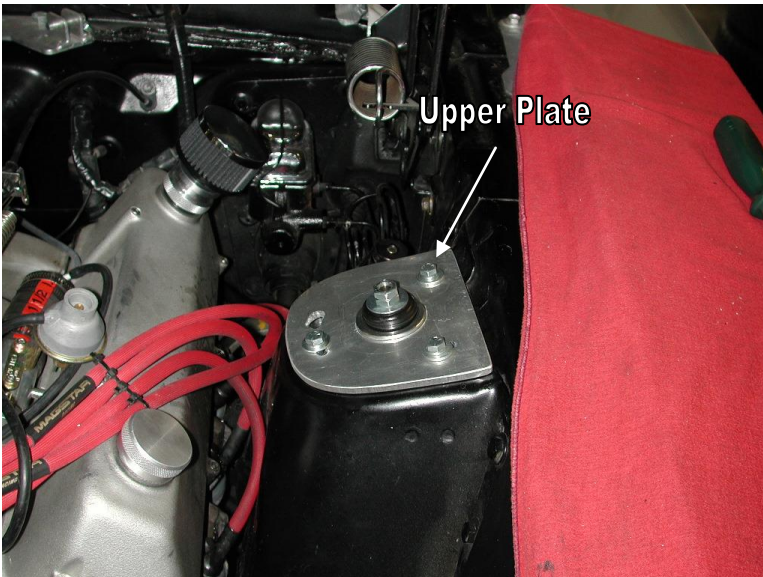

1. Place the upper plate on top of the strut tower. While holding the upper Shockwave mount up to the bottom of the strut tower, fasten the assembly with three 5/16" x 1" flange bolts.



2. Place the stud up through the upper mount. (See diagram)

3. Attach the bottom of the shock to the upper arm w/ the hardware supplied w/ the upper arm.



350 S. St. Charles St. Jasper, In. 47546
Ph. 812.482.2932 Fax 812.634.6632
www.ridetech.com

Part # 12102899
67-70 Mustang Lower StrongArms

Components:

1	90000110	Driver side lower arm
1	90000111	Passengers side lower arm
2	90000895	Lower ball joint
2	90002283	Balljoint castle nut spacer
4	90000112	Eccentric eliminator
2	90000108	Inner bushing sleeve
4	90001086	Poly bushing half
2	90001045	Control arm pivot bearing
2	90000734	Bearing housing
2	90000109	Bearing retaining plate
2	90000733	Aluminum bearing spacer
2	90000732	Bearing stud (Set to 2- 15/16")
2	99250001	1/4-28 grease fitting – Use Lithium grease on frame bushings

Hardware:

2	99501022	1/2"-13 x 4 1/2" Gr.5 bolt	Lower arm to frame
2	99502001	1/2"-13 Nylok nut	Lower arm to frame
6	99371019	3/8"-16 x 1 1/2 SHCS	Bearing housing
6	99373005	3/8" lock washer	Bearing housing
2	99752004	3/4"-16 Jam nut	Stud to arm
2	99752001	3/4"-16 Lock nut	Stud to bearing
2	99753002	3/4" x 2" flat washer	Stud to bearing

Installation Instructions

1. Raise and support vehicle at a safe, comfortable working height. Let the front suspension hang freely.
2. Remove the coil spring, shock absorber, upper shock bracket, strut rod, sway bar, upper and lower control arms. Refer to factory service manual for proper disassembly procedure.



3. Be sure to remove the outer bushing sleeve from the strut rod frame mount.

4. Remove any excess undercoating or rust.



5. Using the bushing retainer as a template, mark the holes to drill with a center punch.

6. Remove the retainer and drill the holes with a 3/8" bit.

7. Place the bearing inside the bearing housing, then clamp it to the frame with the bearing retainer and the 3/8" x 1 1/2" SHCS and lock washers.

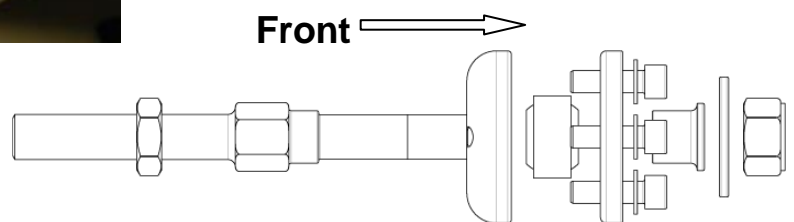



8. The bearing stud should already be threaded into the lower arm, factory set at 2-15/16" (measuring from the end of the arm to the bearing).

9. Slide the stud through the bearing, then slide the aluminum spacer over the stud with the larger end toward the front of the car. Secure the assembly with a 3/4" Nylok Nut and flat washer.

Note: The caster setting should be set at around 3.5 degrees positive. Vehicle must be aligned before driving.



10. Attach the other end of the lower control arm to the factory frame mount using a 1/2" x 4 1/2" bolt and Hex nut.

11. Eccentric eliminator plates are included and one must be installed on each side of the frame. Start out with it in the center, make sure both plates are in the same position.

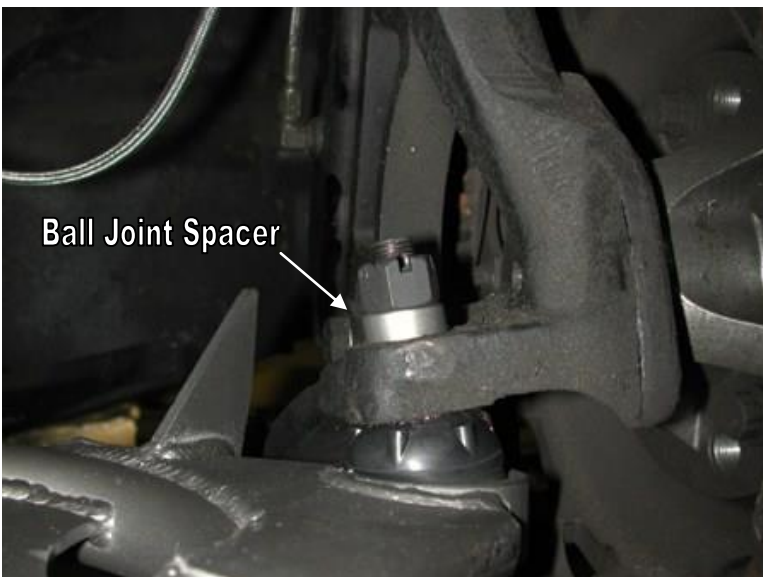

12. Slide the ball joint boot over the ball joint, then place the spindle over the ball joint stud. A ball joint spacer will be necessary to align the castle nut with the cotter pin hole. Grease ball joint

Note: Before installing the spindle, turn the ball joint stud so that the cotter pin hole faces front to back. This will make it easier to install/remove the cotter pin.

13. Lubricate control arm bushing with Lithium grease.



350 S. St. Charles St. Jasper, In. 47546
Ph. 812.482.2932 Fax 812.634.6632

www.ridetech.com

Part # 12103699
67-70 Mustang Upper StrongArms
For Use w/ Shockwaves or CoilOvers

Components:

2	90000115	Upper StrongArm
2	90000930	Upper ball joint
2	90000931	Billet Aluminum drop cross shaft
4	90001589	Heim ends – 3/4"-16 thread x 5/8" I.D.
2	90000113	Alignment shim

Hardware:

4	99621021	5/8"-18 x 2" Gr.8 bolt	Rod end to cross shaft
4	99623001	5/8" SAE Gr. 8 Flat washer	Rod end to cross shaft
4	99623002	5/8" Gr. 8 Lock washer	Rod end to cross shaft
4	99501003	1/2"-13 x 2 1/2" Gr.5 bolt	Cross shaft to body
4	99502006	1/2"-13 nut	Cross shaft to body
8	99503001	1/2" SAE flat washer	Cross shaft to body
4	99503002	1/2" lock washer	Cross shaft to body
2	99501010	1/2"-20 x 2 1/4" Gr.8 bolt	Shockwave/CoilOver to upper arm
2	99502003	1/2"-12 Thin Nylok nut	Shockwave/CoilOver to upper arm
4	99752004	3/4"-16 jam nut	Heim ends

STRONG ARMS™

by Air Ride Technologies

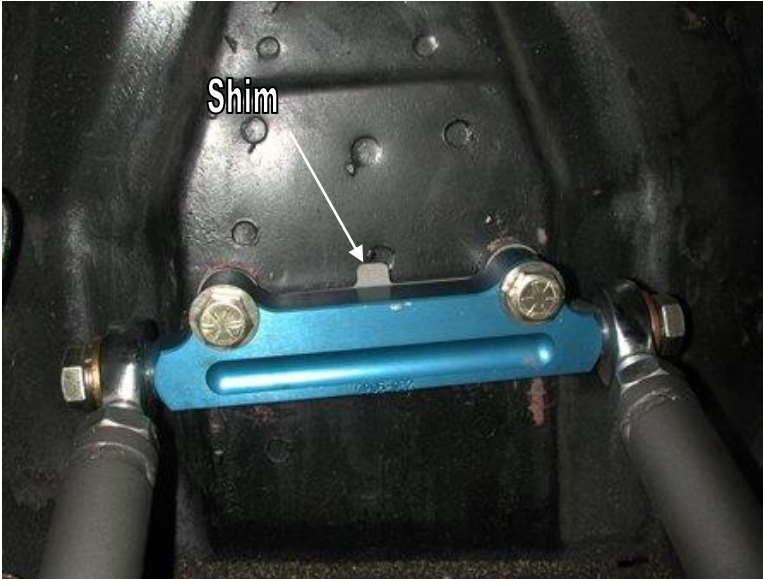

1. Bolt the upper StrongArm to the body using $\frac{1}{2}$ " x $2\frac{1}{2}$ " bolts, flat washers and lock washers. A shim is supplied and may need to be installed between the body and the arms to achieve proper alignment.

2. The arms are preset at the factory so the alignment should be close, but the vehicle must be aligned before driving.

Note: The upper arm mounting holes on many cars have been redrilled 1" lower. This is done to improve the handling. Our cross shaft has the drop built into it, **make sure to use the factory mounting holes.**



3. Bolt the upper arm to the spindle using the hardware and cotter pin supplied.

4. Attach the Shockwave to the upper StrongArm using a $\frac{1}{2}$ " x $2\frac{1}{4}$ " bolt and Nylok nut.

5. This control arm is designed to work with our MuscleBar sway bar. The end link will attach to the **rear** mounting tab on the upper arm.

STRONG ARMS™

by Air Ride Technologies

Item #	Description	Qty.
1.	Control arm	1
2.	Heim ends – 3/4"-16 thread x 5/8" I.D.	2
3.	Alignment shim	1
4.	Cross shaft	1
5.	Ball joint	1
6.	1/2"-13 x 2 1/2" Gr.5 bolt	2
7.	1/2" SAE flat washer	4
8.	1/2" lock washer	2
9.	1/2"-13 nut	2
10.	1/2"-13 x 2 1/4" Gr.5 bolt	1
11.	1/2"-13 Nylok nut	1
12.	5/8"-18 x 1 3/4" Gr.8 bolt	2
13.	5/8" lock washer	2
14.	5/8" flat washer	2

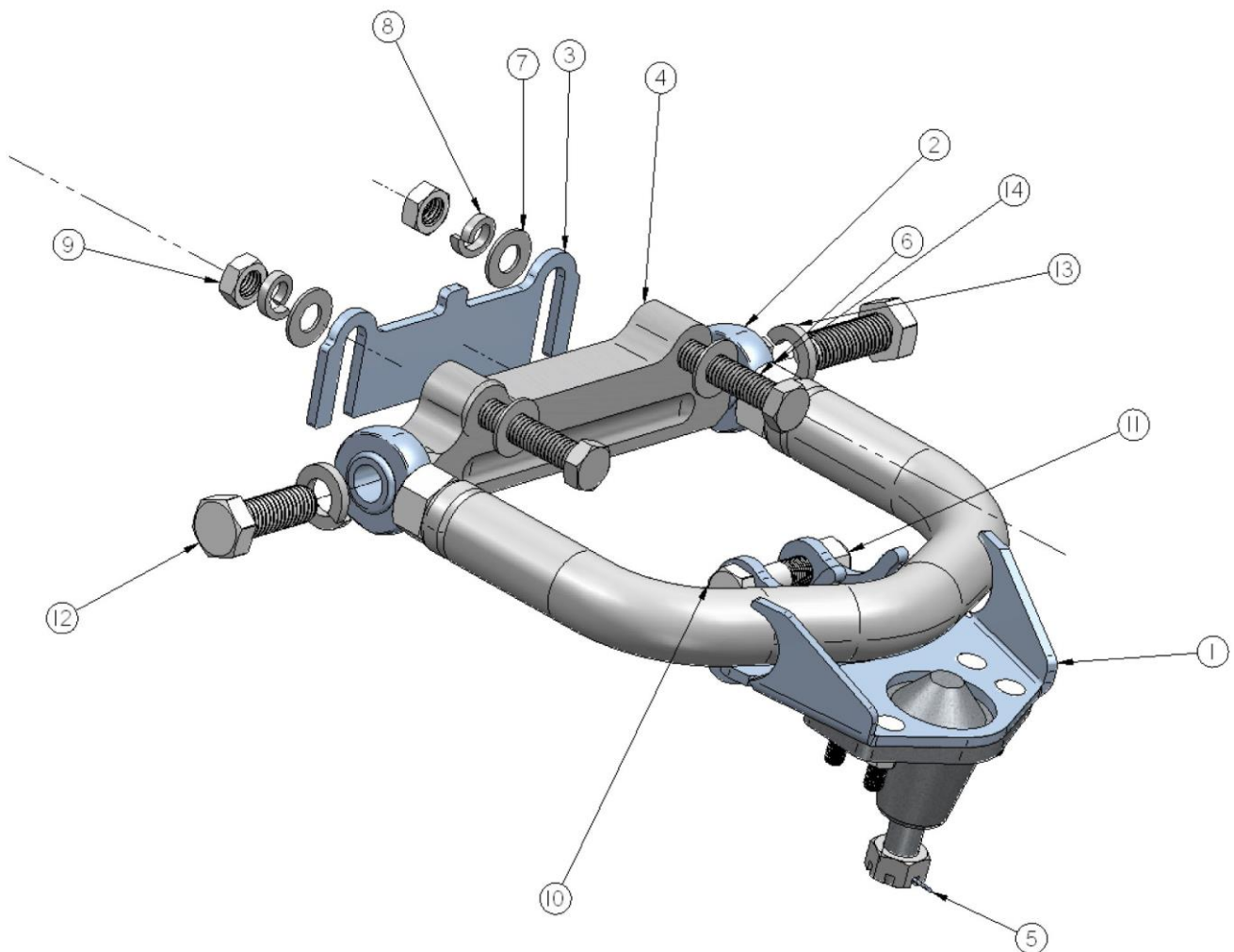



350 S. St. Charles St. Jasper, In. 47546
Ph. 812.482.2932 Fax 812.634.6632
www.ridetech.com

Part # 12109100
67-70 Mustang Front MuscleBar

- 1 90001783 Sway Bar (Includes the following)
 - 2 Frame bushing
 - 2 Frame bracket
- 2 90000114 3" PosiLink spacer
- 4 90000717 PosiLink T-bushing
- 2 90000926 10mm 90 degree PosiLink
- 2 90000924 10mm straight PosiLink
- 1 90001092 Tube of lithium grease
- 2 99115003 10mm x 1.5 x 115mm (4 1/2") stud (use Loctite) In PosiLink

Hardware Kit: 99010046

- 4 99371005 3/8" x 1 1/4" USS bolt Frame bracket
- 4 99372002 3/8" USS Nylok nut Frame bracket
- 8 99373003 3/8" SAE flat washer Frame bracket/PosiLink
- 4 99112002 10mm x 1.5 Nylok nut PosiLink

MUSCLEbar™

POSI•Link™

12109100 Installation Instructions

*****This sway bar is designed to work with our upper StrongArms*****



1. Apply lubricant to the poly bushing, then slide it over the sway bar.
2. Place the sway bar frame bracket over the bushing. Bolt the sway bar to the frame using the 3/8" x 1 1/4" bolts, Nylok nut and flat washers supplied.

Note: Do not tighten the frame bolts until after the PosiLinks are installed.



3. Attach the 90 degree end of the PosiLink to the rear tab of the upper control arm using a 10mm Nylok nut and a 3/8" flat washer on each side of the tab.

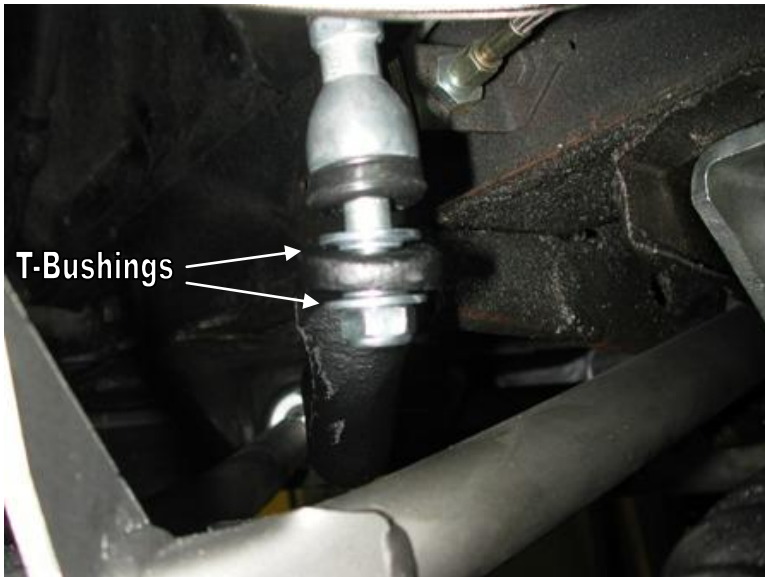

4. Slide a T-bushing over the straight end of the PosiLink, then slide it through the sway bar. Another T-bushing will be installed on the bottom along with a 10mm Nylok nut.



5. The frame bolts can now be tightened.

6. Check sway bar and PosiLink clearance through full suspension travel.

7. Ensure that the PosiLinks do not bind through full suspension travel.





350 S. St. Charles St. Jasper, In. 47546
Ph. 812.482.2932 Fax 812.634.6632
www.ridetech.com

Part # 12106511
67-70 Mustang/Cougar TQ Series Rear CoilOvers
For Use w/ RideTech 4 Link

Shock Assembly:

- | | | |
|---|----------|---|
| 2 | 24359999 | 5" stroke TQ Series Adjustable shock |
| 2 | 90002024 | 1.7" eyelet w/Adjustment knob |
| 4 | 90001994 | .625" I.D. bearing |
| 8 | 90001995 | Bearing snap ring |
| 4 | 90002221 | Reservoir Mount |

Components:

- | | | |
|----|----------|--|
| 2 | 59120175 | Coil spring – 12" long / 175 # rate |
| 2 | 90002222 | Spring retainer kit |
| 8 | 90002043 | Aluminum spacer for bearings |
| 4 | 70010828 | Delrin Spring Washer |
| 12 | 99050000 | 4mm Socket Head Screw Reservoir Mount |

COILOver



Part # 12117199 -1967-1970 Cougar Rear Bolt-in 4 Link

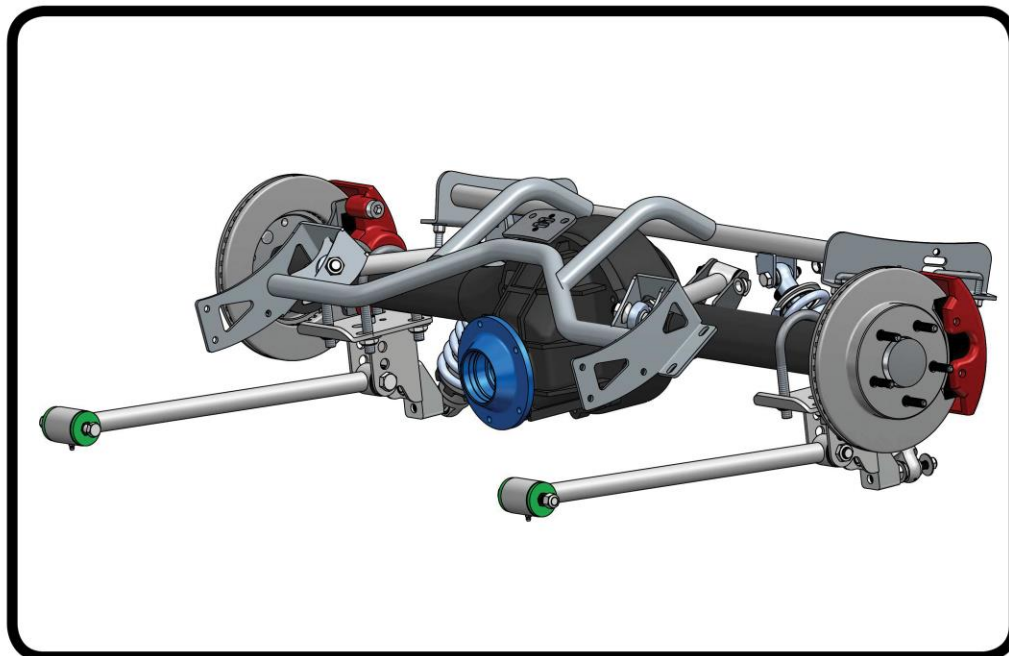

Recommended Tools

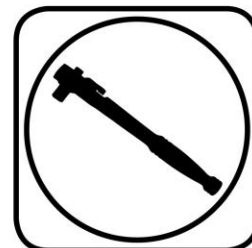

1967-1970 Cougar Rear Bolt-in 4 Link Installation Instructions

Table of contents

Page 2.....	Included components
Page 3.....	Hardware List and Getting Started
Page 4.....	Cradle Installation
Page 5.....	Lower Axle Mount & Lower Bar Installation
Page 6.....	Setting Pinion Angle
Page 7.....	Upper Bar Axle Tab Installation
Page 8.....	Installing Axle Tabs
Page 9.....	Installing ShockWaves/CoilOvers





Major ComponentsIn the box

Item #	Part #	Description	QTY
1	90002198	Upper Cradle	1
2	90000615	Lower Axle Mount	2
3	90002439	Lower Bar Assembly - 24 5/8" " center to center	2
4	90001085	Front Lower Bar Bushing (installed in bar)	4
5	90000519	Front Lower Bar Inner Sleeve (installed in bar)	2
6	90000946	Upper Bar - 11 3/4" center to center	2
7	90001589	Upper Bar Heim End (installed in upper bar)	2
8	90001942	Rubber Bushings (installed in bars)	4
9	70011897	Inner Upper Bar Tab - Short	2
10	70012018	Outer Upper Bar Tab - Tall	4
11	90001642	Aluminum Lower Shock Mount	2
12	90001617	Lower Shock Stud	2
13	90000552	Heim End Spacers	4
14	90002285	Square U-Bolts	7
15	99566001	Axle U-Bolts (+99566002 & 99566003)	4
16	99752004	3/4" -16 Jam Nut (installed on upper bar Heim)	2
17	99250001	Grease Zerks (installed in lower bars)	2
	90002067	Lower Shock Spacers	4
	70010694	Bar Tab Setting Jig	2

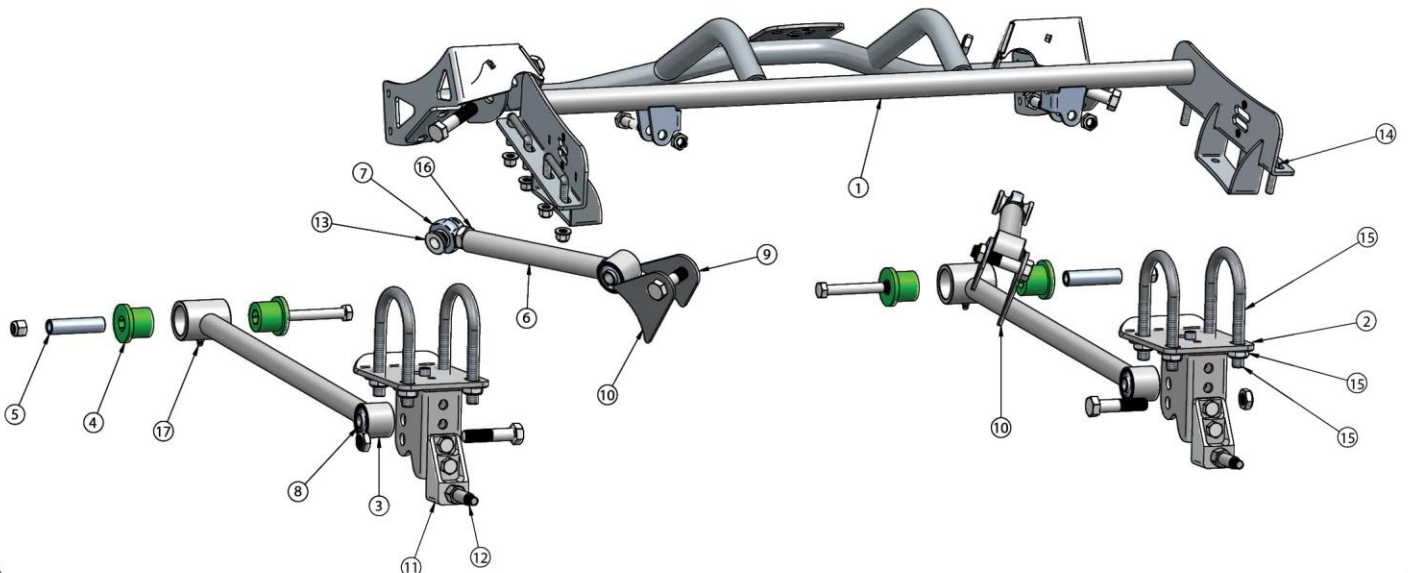



Hardware ListIn the box (Kit# 99010054)

QTY	Part Number	Description	
6	99621003	5/8" x 2 3/4" Gr. 8 Bolt	4-Link Bars to Mounts
6	99622006	5/8" SAE Nylok Jam Nut	4-Link Bars to Mounts
14	99372002	3/8"-16" Nylok Nut	Cradle to Car
14	99373003	3/8" SAE Flat washer	Cradle to Car
6	99373007	3/8" -16 Thread Forming Bolts	Cradle to Car
2	99501010	1/2" -20 x 2 1/4" Hex Bolt	Shock to Cradle
2	99502003	1/2" -20 Thin Nylok Jam Nut	Shock to Cradle
2	99501007	1/2" -20 x 1 1/4" Hex Bolt	Shock Mount to Axle Mount
2	99501009	1/2" -20 x 1 3/4" Hex Bolt	Shock Mount to Axle Mount
4	99502002	1/2" -20 Nylok Nut	Shock Mount to Axle Mount
2	99501029	1/2" -20 x 6 1/2" Hex Bolt	Front Lower bar to Chassis
2	99501017	1/2" -20 x 4 1/2" Hex Bolt	Front Lower Bar to Chassis
2	99502002	1/2" -20 Nylok Nut	Front Lower Bar to Chassis
2	99371001	3/8" -16 x 3/4" Hex Bolt	Bar Setting Jig
2	99372004	3/8" -16 Hex Nut	Bar Setting Jig

Getting Started.....

Congratulations on your purchase of the Ridetech Rear 4-link System. This system has been designed to give your Cougar excellent handling along with a lifetime of enjoyment. Some of the key features of this system: Tune ability, Replaces the Leaf Springs, this allows the 4-Link to locate the rearend and the CoilOvers/ShockWaves to support the car.

Note: These system is designed for use with the Ridetech Shockwaves or CoilOvers and the MuscleBar swaybar. **The factory shocks and springs will not fit this setup.**

1. Raise the vehicle to a safe and comfortable working height. Use jack stands to support the vehicle with the suspension hanging freely.
2. Support the axle and remove the leaf springs, shocks and tail pipes. Refer to the factory service manual for proper disassemble procedures. You might have to detach the fuel line form the frame rails.



Cradle Installation

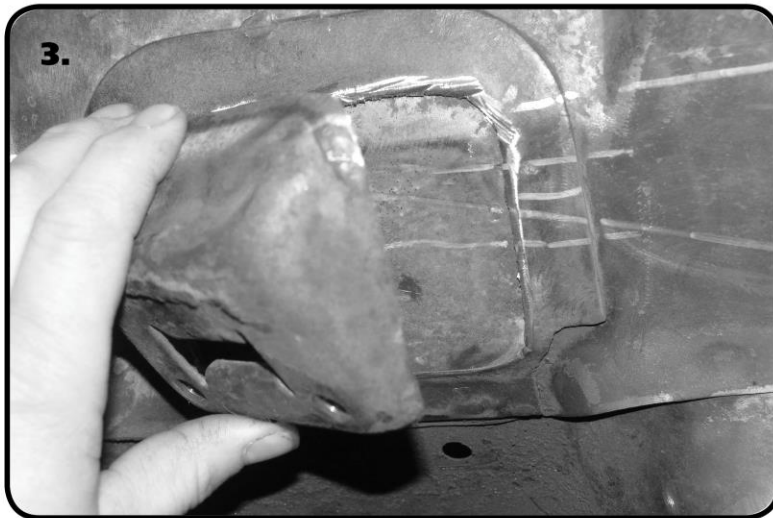

3. Remove the Factory Pinion Snubber and Mount from the car. We use a cut off wheel to remove the mount. Notice that we left the mounting lip of the mount attached to the car. This provides another layer of metal for the Front Tab of the Upper Cradle to attach too. **The Brake Line Tab on the Drivers side will need to be cut loose and relocated. Also, if the car still has the OEM Exhaust Hanger on the Passenger side, it will need relocated.**

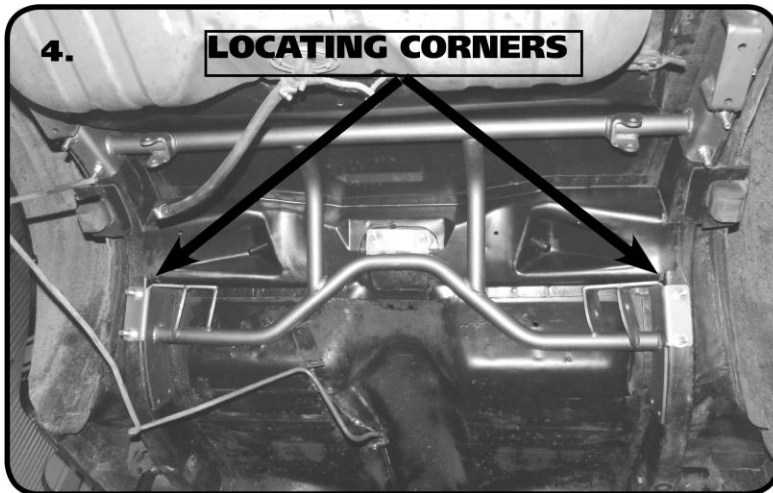

4. Install the cradle into the car. The rear corners of the Upper Bar Mounts locate into the front corner of the factory shock sheet metal mount. The Cradle is held in by (7) 3/8" Square U-bolts. Use the Cradle as a locator for drilling the holes. Drill the holes using a 7/16" drill bit. Drill The front 3 holes on each side with a 5/16" drill bit.

Note: The OEM fuel line will need to be detached from the frame rails until the Cradle is installed.



5. You will notice that the holes are drilled in pairs. Each pair will receive a Square U-bolt. To insert the Square U-bolts into the holes it may be necessary to lower the Cradle to install them. The U-bolts are installed by inserting one end into one of the drilled holes, using the other end as a handle, feed it through the frame until the inserted end will drop down through the remaining hole. Do this for all (7) U-bolts. Install the Cradle into position. Install (1) 3/8" Flat washer and (1) 3/8" Nylok nut onto each stud sticking through the cradle. Do not tighten them until all Washers and Nuts are installed. Install the 3/8" Thread Forming bolts into the 5/16" holes.

www.ridetech.com

812-482-2932



Lower Axle Mount & Lower Bar Installation

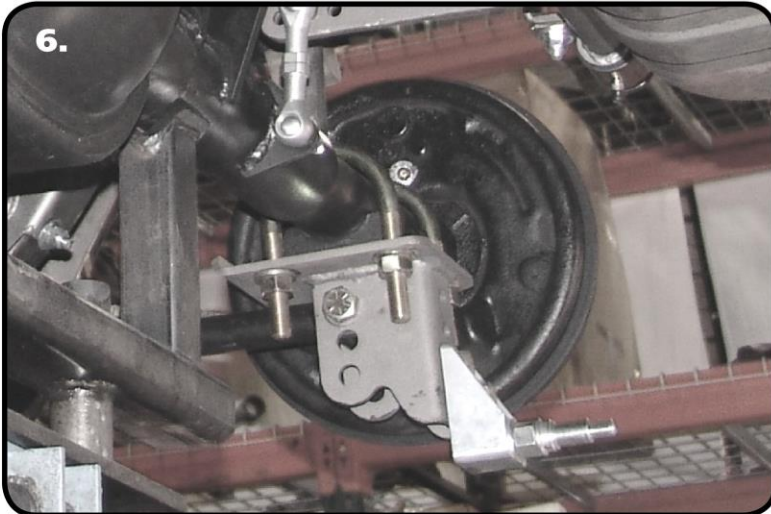

6. Install the Lower Axle Mount onto the Axle using the supplied U-Bolts. Run the nuts down to hold the mount in place, but **DO NOT** tighten yet.

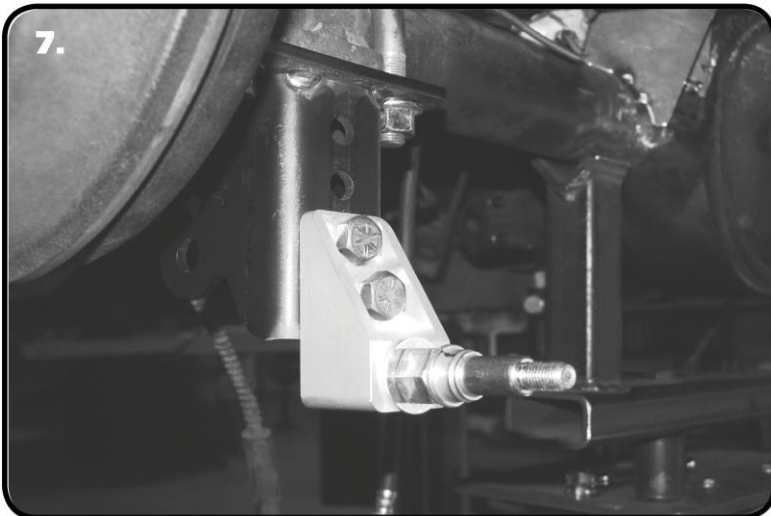

7. Attach the Lower Shock Mount to the Axle Mount using (1) 1/2"-20 x 1 1/4", (1) 1/2"-20 x 1 3/4" Hex Bolts, and (2) 1/2"-20 Nylok Nuts on each mount. The Shock Mount is installed in the **BOTTOM 2** holes of the Axle Mount. Install a Shock Stud and 5/8" washer in each Shock Mount. Tighten the mounting hardware and the Shock Stud.

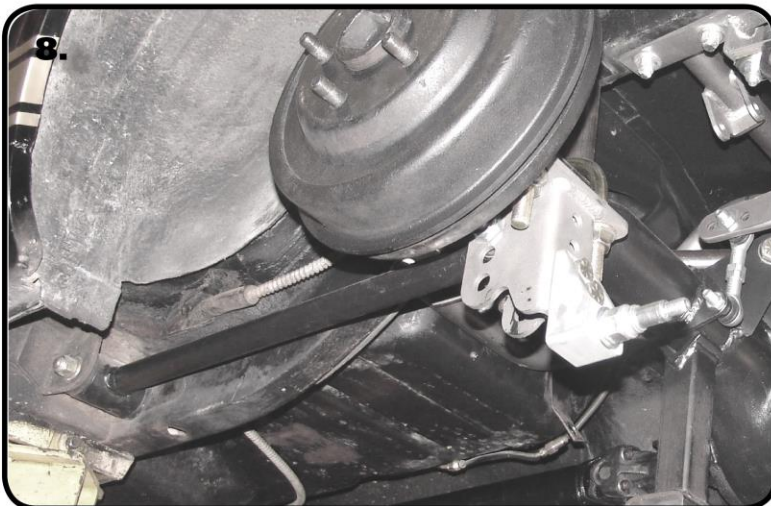

8. Install the Lower Bars with the Grease Zerk pointing down. The bar is attached to the Axle Mount in the **TOP HOLE** using (1) 5/8" x 2 3/4" Hex Bolt, and (1) 5/8" Thin Nylok Jam Nut. The front of the Lower Bar is attached with 1/2"x 6" Hex Bolt(64-67) or 1/2"x 4 1/2"Hex Bolt(68-70), and (1) 1/2" Nylok Nut.

Note: This front bushing is polyurethane and is lubricated at the factory with lithium grease. Future lubrication can be done with any non-petroleum based lubricant. The rubber bushings don't require lubrication.



Setting Pinion Angle

READ PAGES 6-8 ON SETTING PINION ANGLES, UPPER BAR TAB JIG INSTALLATION, & SETTING RIDE HEIGHT.

How do you set the pinion angle? On a single-piece shaft you want to set it up where a line drawn through the center of the engine crankshaft or output shaft of the transmission and a line drawn through the center of the pinion are parallel to each other but not the same line.

A simple way to do this is to place a digital angle finder or dial level on the front face of the lower engine pulley or harmonic balancer. This will give you a reading that is 90 degrees to the crank or output shaft unless you have real problems with your balancer. At the other end, you can place the same level or angle finder against the front face of the pinion yoke that is also at 90 degrees to the center line. If you rotate the yoke up or down so both angles match, you have perfect alignment.

Road testing will tell you if you have it right. If you accelerate and you get or increase a vibration, then the pinion yoke is too HIGH. Rotate it downward in small increments of a degree or two until the problem goes away. If you get or increase a vibration when decelerating, then the pinion yoke is too LOW. Rotate it upward to correct it.

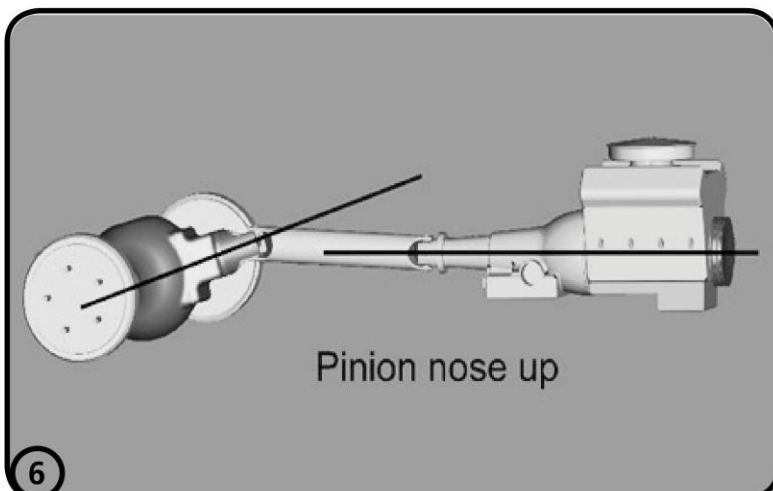
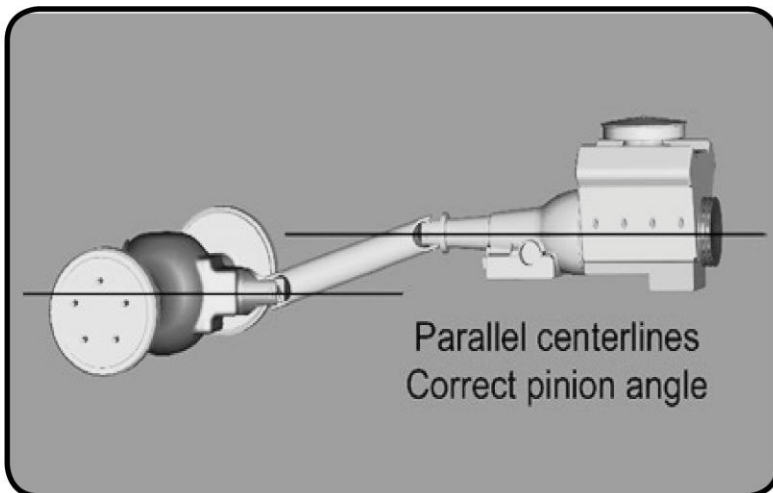
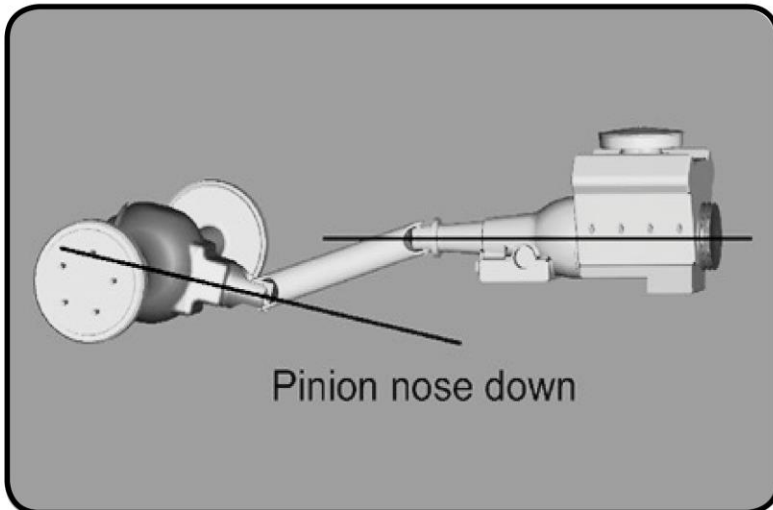



Upper Bar Tab Installation Jig

Upper Bar Installation Jig

- This jig has been supplied to aid in the installation of the upper 4 link bar. It can be temporarily used to properly align, locate and weld the tabs onto the axle. It will also ensure that the mounting bolts are parallel to the ground.
- Follow the diagram below to set the jig to the same length as the upper bar, use the 3/8" x 3/4" bolt and nuts to set the length.
- Position the axle at ride height. Center the axle left to right between the quarter panels. Set pinion angle.
- Bolt one end of the jig to the cradle using a 5/8" x 2 3/4" bolt.
- Using another 5/8" x 2 3/4" bolt, fasten the axle tabs to the other end. The tall tab goes to the outside of the car. The short tab goes to the inside of the car. The tabs must be bolted to the outside of the jig.
- Swing the bar down letting the tabs rest onto the axle. Trim the brackets as necessary to minimize the gap to be welded.
- Check pinion angle, ride height and axle center. Tack-weld the tabs in place.
- Remove jig and install upper bar.
- Repeat this process for the other side.
- Recheck pinion angle, ride height and axle center. (Sound familiar?)
- After the tabs have been tack welded on both sides, remove the upper bars to avoid melting the rubber bushings. Let the axle drop down for better access to the tabs. Lay 1" welds on the inside and outside of the tabs. Skip around from one side to the other to avoid overheating the tube.

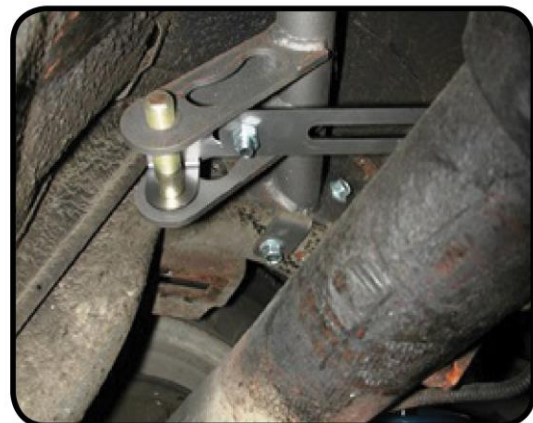
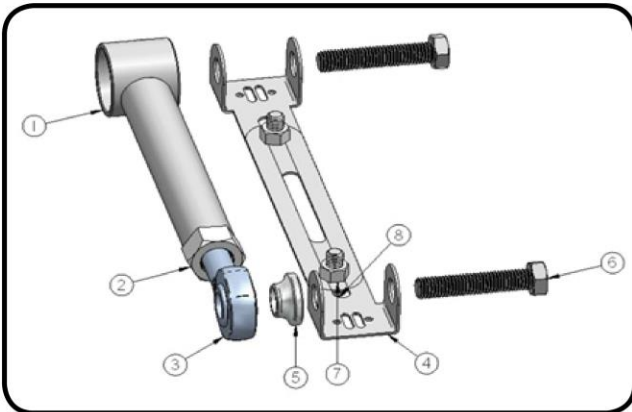

Item#	Description
1	Upper Bar
2	3/4"-16 Jam Nut
3	Heim End
4	Alignment Jig
5	Aluminum Spacer
6	5/8" x 2 3/4" Bolt
7	3/8"-16 Nut
8	3/8"-16 x 3/4" Bolt



Installing Axle Tabs

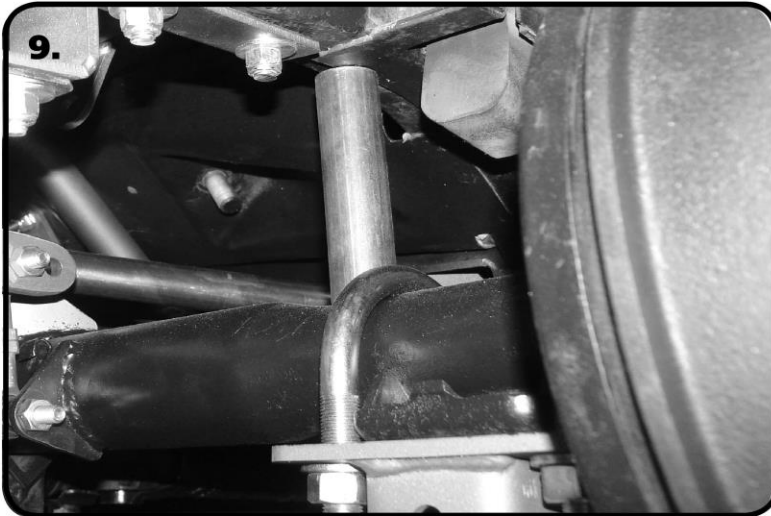

9. One helpful trick to maintain ride height when setting the pinion angle is to put a spacer between the axle and the frame. The spacer should be 4 1/2" tall. Set the pinion Angle and axle center. When measuring the axle center you can measure off of the frame rails. We also use a plum bob off the quarter panels to double check the axle center. Refer to Page 6 on Setting the Pinion Angle.

Note: You can tack weld the spacer in place after you get the Pinion Angle, and Axle Center set. This will ensure that nothing moves through the Upper Tab Installation.

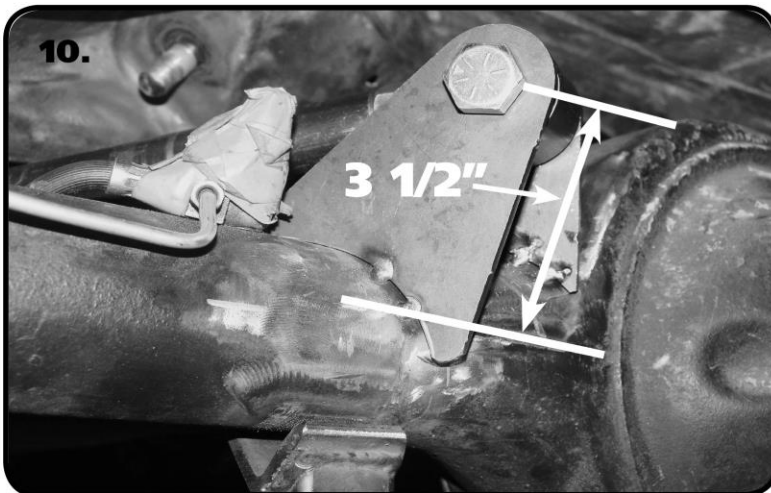

10. Refer to Page 7 and set the length of the Upper Bar Jig and install the Tabs on the Jig. Insert the Jig into the Cradle. Set the Upper Tabs on the Rearend. Due to different variations of the Rearend Housings, it may be necessary to modify the tabs for the best fit. The height you are wanting to achieve with the upper bar end is 3 1/2" from the axle center line. Modify the tabs so that the center of the bar bushing will be 3 1/2" from the center of the axle.

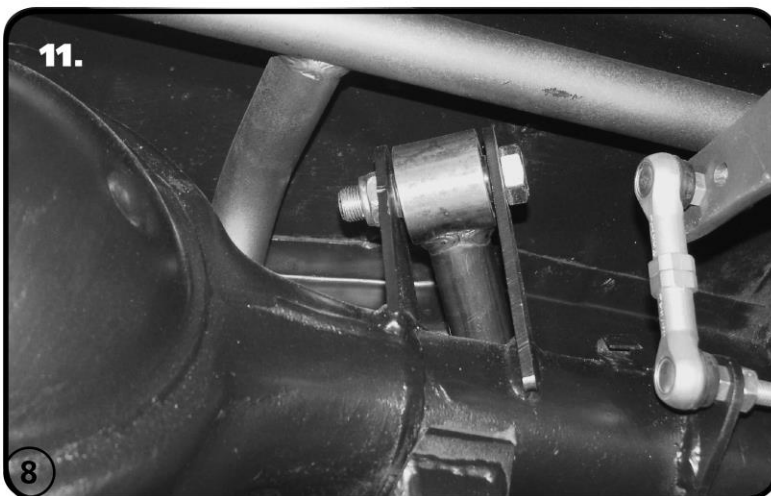

11. Once the bar end height is set, tack weld the tabs to the axle. Do this for the Driver and Passenger side bars. Insert the bars into the Cradle and Tabs to double check fitment. Recheck Axle Center and Pinion Angle. Once satisfied with fitment weld the Upper bar Tabs onto the Axle. Weld 1" at a time, skip around from one side to the other, and one tab to the other to avoid overheating the Axle Tube. When the tabs cool down, install the upper bars using (1) 5/8" x 2 3/4" Bolt, and (1) 5/8" Thin Nylok Nut.



Installing Shockwaves/Coilovers

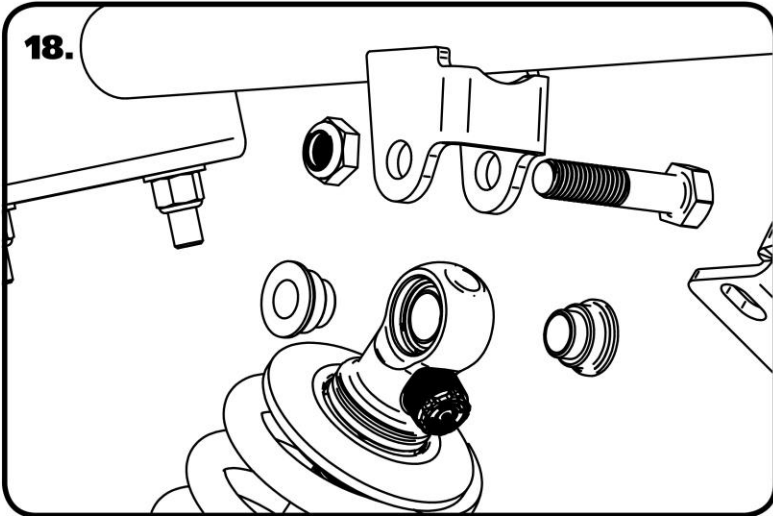

Remove the Spacer from between the Axle and Frame.

18. Install a 1/2" ID Spacer on each side of the upper Coilover/ShockWave. Slide the assembly into the upper crossmember from the bottom side. If your shock has an adjuster knob position it so that the knob points toward the center of the car. Line up the hole in the spacers with the hole in the upper shock bridge and insert 1/2" x 2 1/2" bolt and install 1/2" Nylok nut.

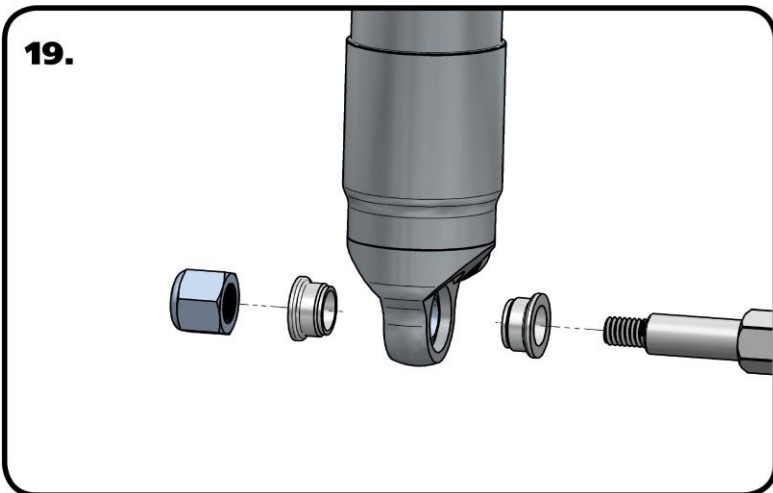

20. Install a 5/8" ID spacer(Small side towards shock body) onto the lower Shock Stud. Slide the bottom of the Shock onto the Stud. Install a second 5/8" ID Spacer onto the Stud(small side towards shock). You may need to jack the rearend up to Slide the Shock onto the Stud. Install the 7/16" Flatwasher and 7/16" Nylok nut. Tighten the upper and lower shock bolts.

Note: If installing Shockwaves and you want to locate the air fitting in a different location, the air spring assembly can be rotated on the shock by grabbing the shock and air spring assembly by hand and spinning the shock in the air spring assembly.

The designed ride height of the CoilOver/Shockwave is 14 1/2" center to center.

STILL HAVE QUESTIONS?

Tech line hours

Monday - Friday

8AM - 6PM (EST) 812-482-2932

www.ridetech.com

812-482-2932



350 S. St. Charles St. Jasper, In. 47546

Ph. 812.482.2932 Fax 812.634.6632

www.ridetech.com

Part # 12106510
67-70 Mustang/Cougar HQ Series Rear CoilOvers
For Use w/ RideTech 4 Link

Shock Assembly:

2	24159999	5" stroke HQ Series shock
2	90002024	1.7" eyelet – w/adjustment knob
4	90001994	.625" I.D. bearing
8	90001995	Bearing snap ring

Components:

2	59120175	Coil spring – 12" long / 175 # rate
2	90002222	Spring retainer kit
8	90002043	Aluminum spacer for bearings
4	70010828	Delrin Spring Washer



350 S. St. Charles St. Jasper, In. 47546

Ph. 812.482.2932 Fax 812.634.6632

www.ridetech.com

Ride Height

We have designed most cars to have a ride height of about 2" lower than factory. To achieve the best ride quality & handling, the shock absorber needs to be at 40-60% overall travel when the car is at ride height. This will ensure that the shock will not bottom out or top out over even the largest bumps. Measuring the shock can be difficult, especially on some front suspensions. Measuring overall wheel travel is just as effective and can be much easier. Most cars will have 4-6" of overall wheel travel. One easy way to determine where you are at in wheel travel is to take a measurement from the fender lip (center of the wheel) to the ground. Then lift the car by the frame until the wheel is just touching the ground, re-measure. This will indicate how far you are from full extension of the shock. A minimum of 1.5" of extension travel (at the wheel) is needed to ensure that the shock does not top out. If you are more than 3" from full extension of the shock then you are in danger of bottoming out the shock absorber.

Adjusting Spring Height

When assembling the CoilOver, screw the spring retainer tight up to the spring (0 preload). After entire weight of car is on the wheels, jounce the suspension and roll the car forward and backward to alleviate suspension bind.

- If the car is too high w/ 0 preload then a smaller rate spring is required. Although threading the spring retainer down would lower the car, this could allow the spring to fall out of its seat when lifting the car by the frame.
- If the car is too low w/ 0 preload, then preload can then be added by threading the spring retainer up to achieve ride height. On 2.6" - 4" stroke shocks, up to 1.5" of preload is acceptable. On 5-7" stroke shocks, up to 2.5" of preload is acceptable. If more preload is needed to achieve ride height a stiffer spring rate is required. Too much preload may lead to coil bind, causing ride quality to suffer.

ridetech

Assembly...



First using the supplied lower adjuster nut(90002222) thread the nut onto the shock from the bottom side as seen in figure 1



Next install delrin washers then coil spring over the top of the shock as seen in figure 2



Before the upper spring mount can be installed screw the adjuster knob on the upper eye mount to the firmest setting (clockwise) as seen in figure 3.



Slide the Derlin washer over the spring, Next slide the upper spring mount (90002222) over eyelet as seen in figure 4.



Install upper spring mount retainer clip (90002057) into the groove on the upper eyelet as seen in figure 5. Then reinstall adjuster to complete assembly.



The included set of bearing spacers (900002044) are used to adapt the coil-overs to just about any application. The supplied spacers allow the coil-overs to accept 5/8" or 1/2" bolts.

Shock adjustment 101- Single Adjustable

Rebound Adjustment:

How to adjust your new shocks.

The rebound adjustment knob is located on the top of the shock absorber protruding from the eyelet.

You must first begin at the ZERO setting, then set the shock to a soft setting of 20.



-Begin with the shocks adjusted to the ZERO rebound position (full stiff). Do this by rotating the rebound adjuster knob clockwise until it stops.



-Now turn the rebound adjuster knob counter clock wise 20 clicks. This sets the shock at 20. (settings 21-24 are typically too soft for street use).

Take the vehicle for a test drive.



-if you are satisfied with the ride quality, do not do anything, you are set!



-if the ride quality is too soft increase the damping effect by rotating the rebound knob clock wise 3 clicks.

Take the vehicle for another test drive.



-if the vehicle is too soft increase the damping effect by rotating the rebound knob clock wise 3 additional clicks.



-If the vehicle is too stiff rotate the rebound adjustment knob counter clock wise 2 clicks and you are set!

Take the vehicle for another test drive and repeat the above steps until the ride quality is satisfactory.

Note:

One end of the vehicle will likely reach the desired setting before the other end. If this happens stop adjusting the satisfied end and keep adjusting the unsatisfied end until the overall ride quality is satisfactory.