

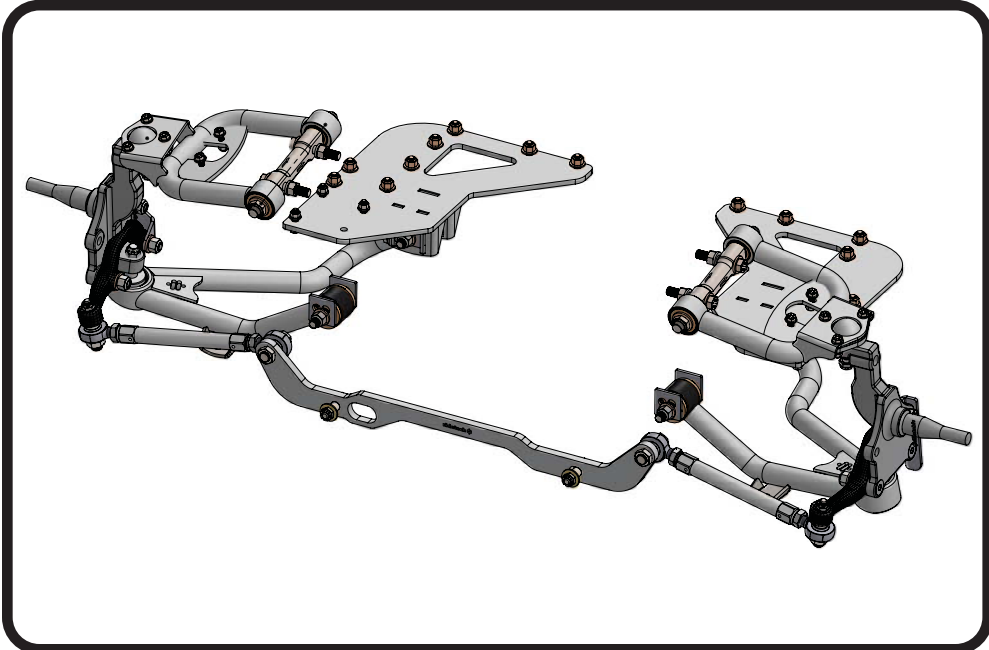

Part # 11259599 - 1962-1967 Chevy II Front TruTurn System

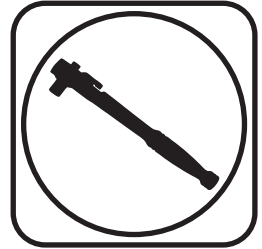

Recommended Tools



1962-1967 Chevy II TruTurn System Installation Instructions

Table of contents

Page 2.....	Major Components
Page 3.....	Upper Control Arm Components
Page 4.....	Lower Control Arm Components
Page 5.....	TruTurn Steering Components
Page 6.....	Hardware & Getting Started
Page 7-8.....	Disassembly
Page 9-10.....	Installing Lower Control Arm Mount
Page 10-11.....	Crossmember Installation
Page 11-12.....	Installing Lower Control Arm
Page 13-14.....	Installing Upper Control Arm
Page 14-15.....	Spindle Installation
Page 15-16.....	Centerlink Adapter Installation
Page 17.....	Steering Arm & Stop Installation
Page 18-19.....	Tie-Rod Assembly, Installation & Alignment
Page 20.....	Torque Specifications



Major Components AssembledIn the box

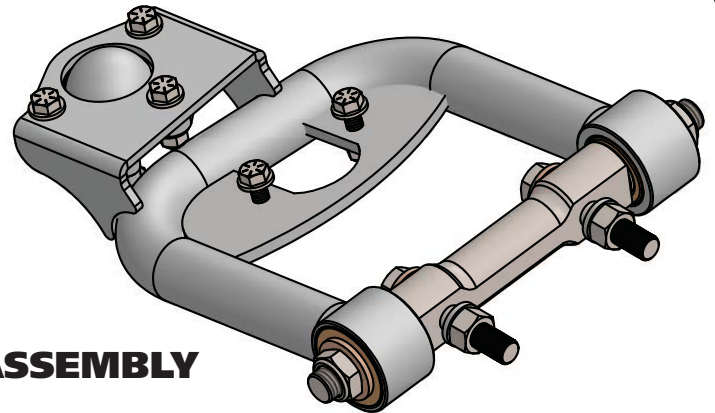

DRIVER UPPER CONTROL ARM ASSEMBLY

Exploded View on Page 3

DRIVER LOWER CONTROL ARM ASSEMBLY

Exploded View on Page 4

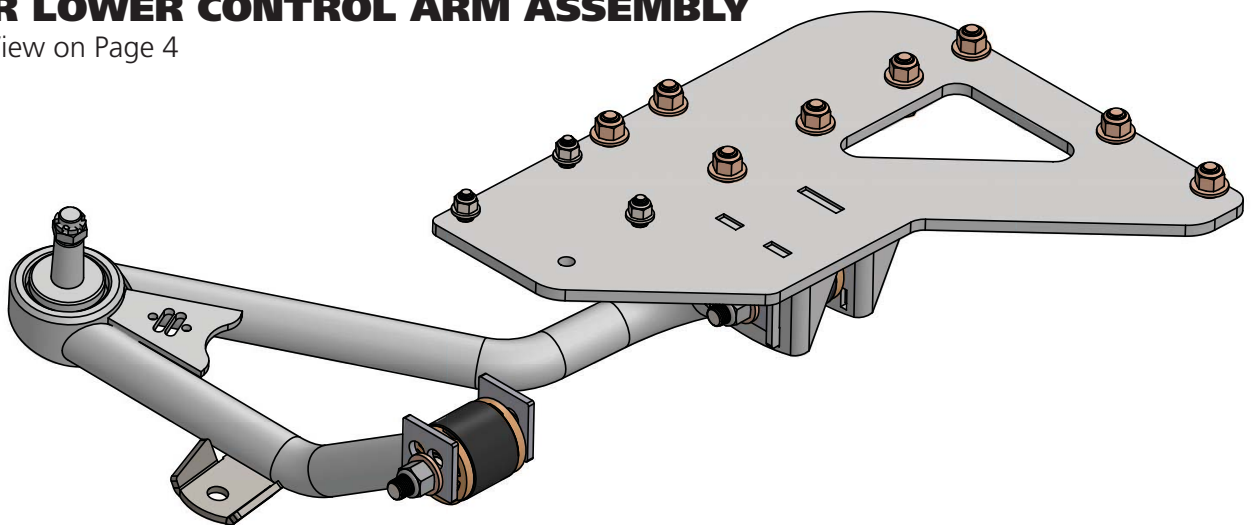

STEERING COMPONENTS ASSEMBLY

Exploded View on Page 5



Upper Control Arm ComponentsIn the box

Item #	Part Number	Description	QTY
1	90003261	Driver Upper Control Arm (Shown)	1
1	90003262	Passenger Upper Control Arm	1
2	90003263	Upper Cross Shaft	2
3	70015252	Delrin Upper Control Arm Bushing	4
4	90003340	Inner Bushing Sleeve	4
5	70010866	Ball joint Assembly	2
6	90002633	Ball joint Spacer	2
7	99311011	5/16"-18 x 1 1/4" Hex Bolt	6
8	99313001	5/16" SAE Flat Washer	12
9	99312002	5/16"-18 Nylok Nut	6
10	99623010	5/8" SAE Flat Washer	4
11	99622006	5/8"-18 Nylok Nut	4

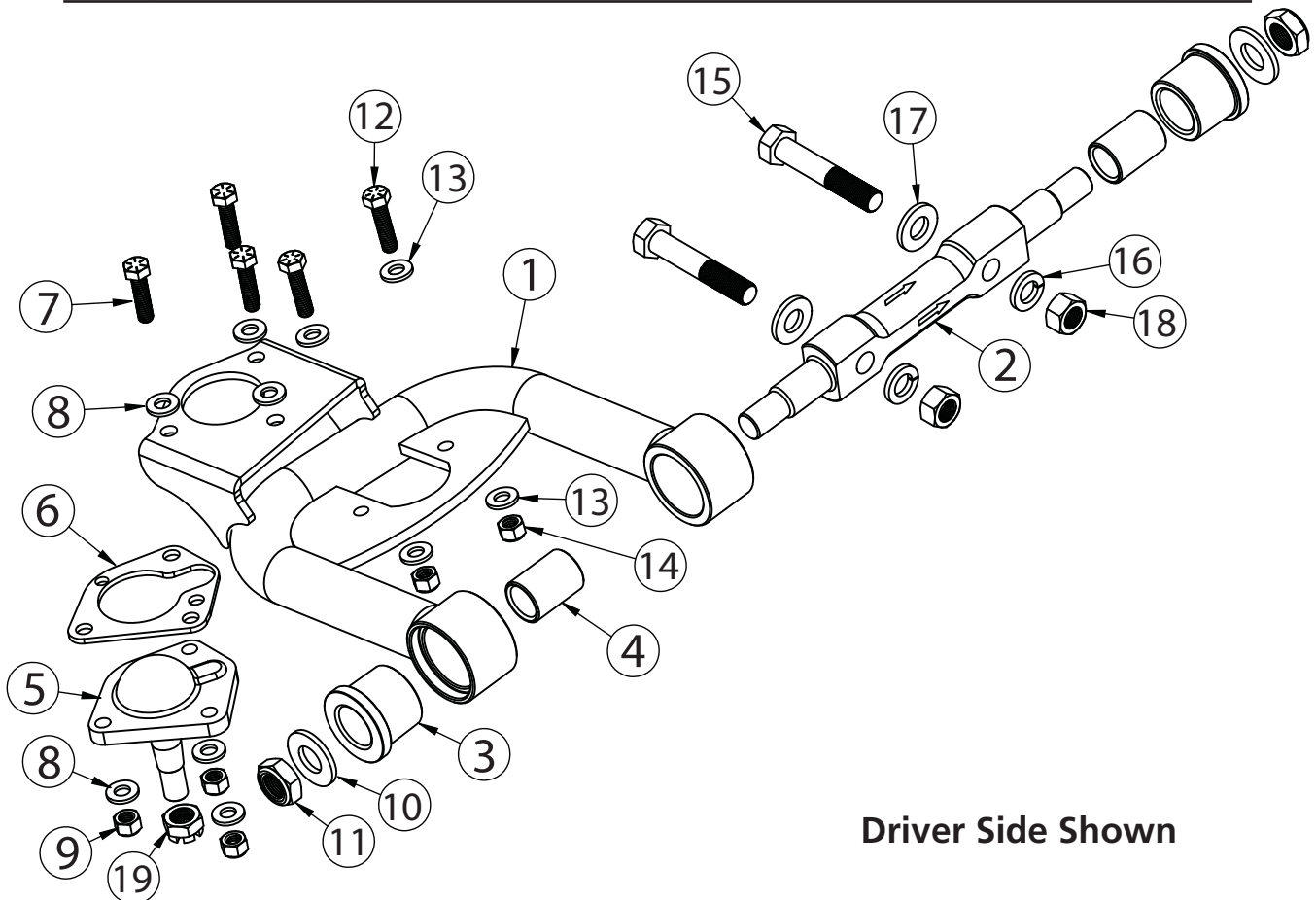



Lower Control Arm ComponentsIn the box

Item #	Part Number	Description	QTY
20	90003264	Driver Lower Control Arm (Shown)	1
20	90003265	Passenger Lower Control Arm	1
21	70010759	Delrin Bushing	8
22	90000549	Delrin Bushing Inner Sleeve	4
23	90000898	Lower Ball joint	2
24	90003338	Lower Chassis Plate - Diver	1
24	90003339	Lower Chassis Plate - Passenger	1
25	90000112	Eccentric Plate	8

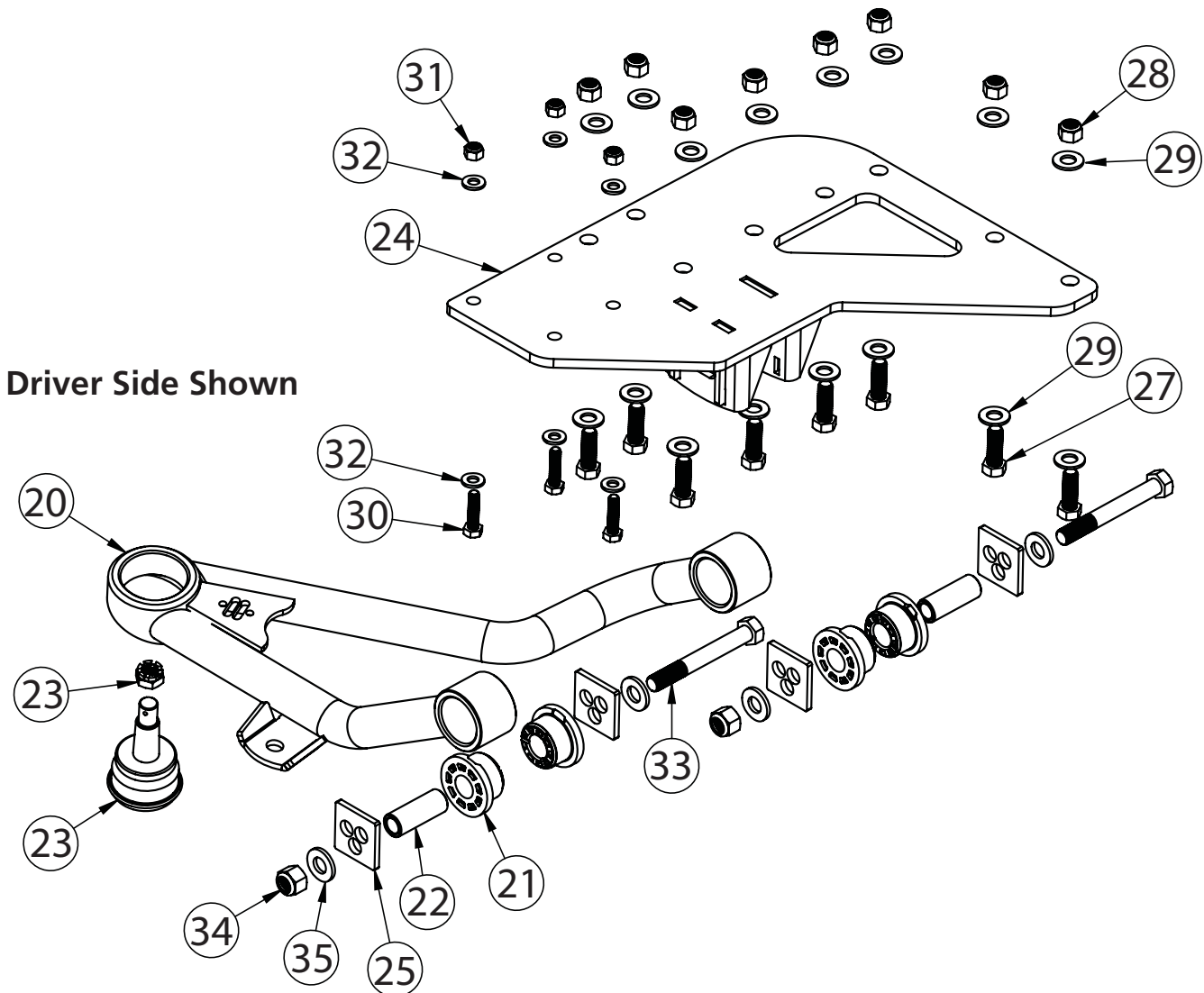



TruTurn Steering ComponentsIn the box

Item #	Part Number	Description	QTY
36	11009300	Ridetech Tall Spindle	1 pr
37	90009933	Drag Link Stud	2
38	90002351	Inner Tie Rod Stud	2
39	90003337	Tie-Rod Adjuster	2
40	90002347	Driver Steering Arm	1
41	90002348	Passenger Steering Arm	1
42	90002349	Bolt On Steering Stop - Driver	1
43	90002350	Bolt On Steering Stop - Passenger	1
44	90001582	Heim End - 5/8"-18 x 5/8" Bolt - RH Thread	2
45	90001590	Heim End - 5/8"-18 x 5/8" Bolt - LH Thread	2
46	90009931	Outer Tie Rod Stud	2
47	90002676	Outer Tie Rod Spacer - 5/8" ID x .125"	4
48	90003329	Drag Link Adapter	1

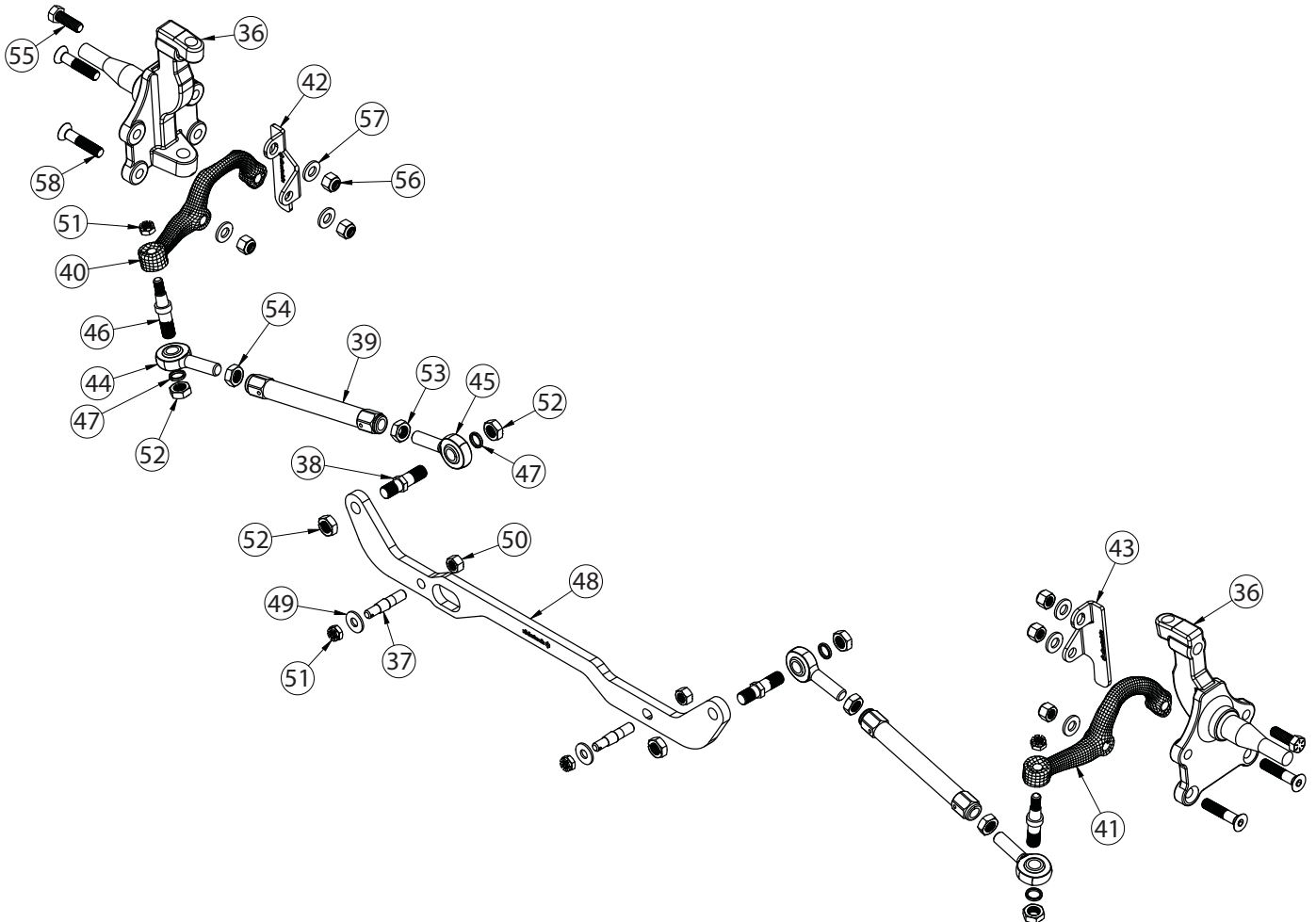



Hardware Shown in DiagramsKit# 99010151

Kit# 99010188

Item #	Shock Mount		QTY
12	99311011	5/16-18 X 1 1/4" HEX CAP SCREW GR8	4
13	99313001	5/16" FLAT WASHER GR8	8
14	99312002	5/16-18 NYLON LOCKNUT GR8	4
Cross Shaft to Car			
15	99501021	1/2-20 X 2.75 HEX BOLT GR8	4
16	99503015	1/2" SPLIT LOCK WASHER GR8	4
17	99503014	1/2" SAE FLAT WASHER GR8	4
18	99502004	1/2-20 HEX NUT GR8	4
Upper Ball Joint To Spindle			
19	99502017	1/2-20 Castle Nut	2

Kit# 99010187

Item #	Chassis Plate		QTY
27	99431021	7/16-14 X 1.25" HEX BOLT GR8	16
28	99432010	7/16-14 NYLON LOCK NUT GR8	16
29	99433005	7/16" SAE FLAT WASHER GR8	32
30	99311011	5/16-18 X 1.25" HEX BOLT GR8	6
31	99312002	5/16-18 NYLON LOCK NUT GR8	6
32	99313001	5/16" SAE FLAT WASHER GR8	12
Lower Control Arms Mounting			
33	99501016	1/2-20 X 4.00" HEX BOLT GR8	4
34	99502002	1/2-20 NYLON LOCK NUT GR8	4
35	99503014	1/2"SAE FLAT WASHER GR8	8

Kit# 99010186

Item #	Drag Link Stud		QTY
49	99433002	7/16" SAE FLAT WASHER	2
50	99502010	1/2-20 MECHANICAL LOCK NUT	2
51	99432005	7/16-20 CASTLE NUT	2
	99952002	3/32" COTTER PIN	2
Outer Tie Rod Stud			
51	99432005	7/16-20 CASTLE NUT	2
52	99622005	5/8-18 THIN MECHANICAL LOCK NUT	2
	99952002	3/32" COTTER PIN	2
Inner Tie Rod Stud			
52	99622005	5/8-18 THIN MECHANICAL LOCK NUT	4
Tie Rod			
53	99800002	5/8-18 LH JAM NUT	2
54	99800003	5/8-18 RH JAM NUT	2
Steering Stop			
55	99501053	1/2-13 X 1.50 HEX BOLT GR 8	2
56	99502009	1/2-13 NYLON LOCKNUT GR8	2
57	99503014	1/2" SAE FLAT WASHER GR8	2
Steering Arm			
58	99501054	1/2-20 FLAT HEAD CAP SCREW	2

Getting Started.....

Congratulations on your purchase of the Ridetech TruTurn System. This System has been designed to give your Chevy II excellent handling along with a lifetime of enjoyment. Some of the key features of the TruTurn System: Ball joint angles have been optimized for the lowered ride height, eliminated rubber bushings to get rid of bushing deflection and provide free suspension movement through the entire range of travel. The geometry has been optimized for excellent handling, driveability and minimal bump steer.

Note: These control arms are designed for use with the Ridetech CoilOvers and the MuscleBar swaybar. **The factory shocks and springs or the factory sway bar will not fit these arms.**

Brake Kits

These spindles are designed around stock disc brake spindles and will accept any disc brake set up designed for those. **The only modification we discovered to be necessary, was a small trim on the bottom of the stamped 1/4" steel caliper bracket that holds the caliper.** It is an area that is not stressed and will not cause any loss of strength. Trim only enough to make the caliper bracket clear the spindle. If you are using the factory dust shields, they will also require trimming. If your car came with drum brakes, be sure to swap to the appropriate disc brake master cylinder and valving.

1. The shocks, coilsprings, control arms, tie rods, and sway bar need to be removed from the car.



Disassembly



2. The OEM strut rod mounts will need to be removed from the car. The strut rod mount is attached to the car with 4 rivets. There is a 5th rivet that attaches the radiator support to the frame rail that will also need removed. We have seen some cars that have a bolt/nut here instead of a rivet.

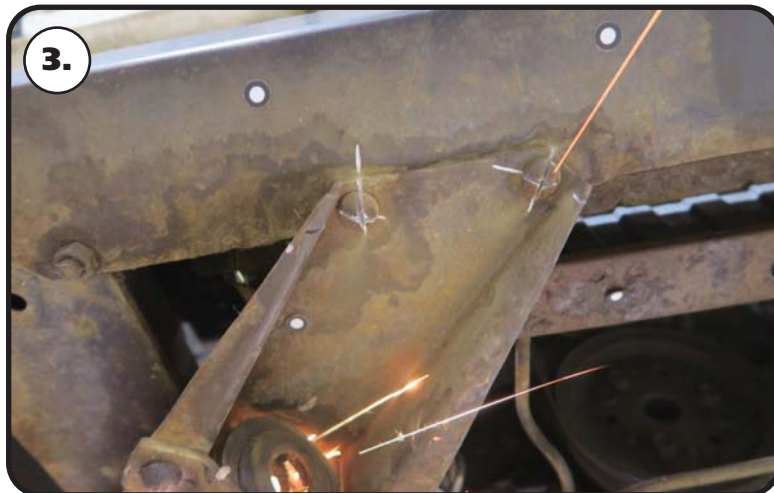

3. We cut a "+" in the head of the rivets.



4. With the "+" cut in the head of the rivet, chisel the head of the rivet off. The head of the rivet should come off in 4 pieces.



Disassembly



5. With the rivet heads removed, the strut rod mount can be removed from the car.



6. The remainder of the rivets will need to be removed from the frame of the car.



7. The crossmember will need to be removed from the car. **The crossmember will be reinstalled later.**



Installing Lower Control Arm Mount

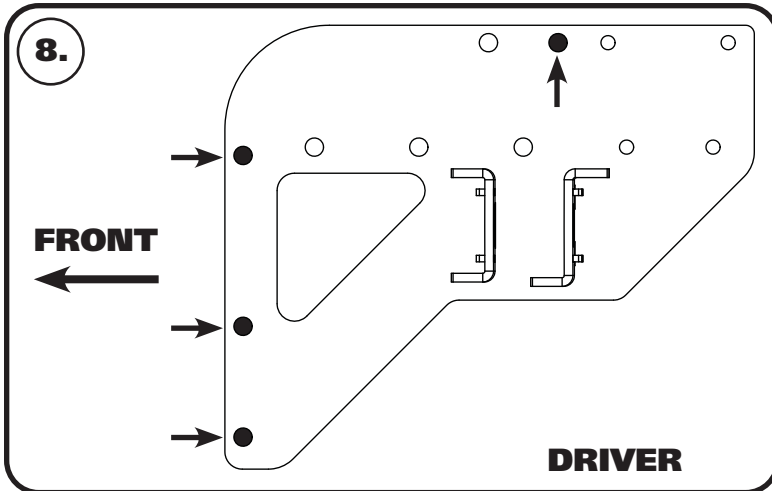

Use **Images 8 - 12** as a guide to install the lower control arm mounts.

8. **Image 8** shows the DRIVER lower control arm mount. The lower control arm mounting plate will attach to some of the OEM rivet holes. The mounting holes that will use the OEM rivet holes are pointed out with arrows in **Image 8**. You may need to use a 7/16" drill bit to clean up the rivet holes that will be used to attached the lower control arm mounting plate. The (4) crossmember mounting bolts will also line up with the crossmember holes in the frame.



9. Align the lower control arm mount with the OEM rivet holes. Install a 7/16" flat washer on each of (4) 7/16"-14 x 1 1/4" bolts. Insert the bolts/washers in the holes that align with the OEM rivet holes. The threads of the bolts need to be pointing up before final tightening. We installed a few of the bolts with the threads pointing down for alignment purposes. We removed them and installed them with the threads pointing up after we got some of the other bolts installed correctly. Install a 7/16" flat washer and 7/16"-14 nylok nut on each of the bolts.



10. Use a 7/16" drill bit to drill the (4) holes in the frame rail that don't exist.



Installing Lower Control Arm Mount



11. Install a 7/16" flat washer on each of (4) 7/16"-14 x 1 1/4" bolts. Insert the bolts/washers in the holes that align with the holes that were just drilled. The threads of the bolts need to be pointing up. Install a 7/16" flat washer and 7/16"-14 nylok nut on each of the bolts. Torque the bolts to 80 ft-lbs. Repeat Step 8-12 on the other side.



13. The crossmember will need to be notched to clear the lower control arm mount. Hold the crossmember up in position to see where you will need to notch it.

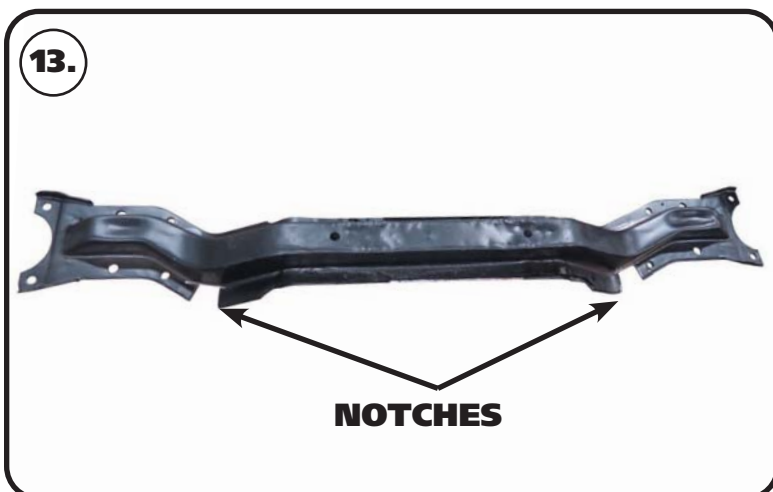

13. Image 13 shows the crossmember after it as been notched.



Installing Crossmember & Lower Control Arm



14. Hold the crossmember in position, aligning it with the mounting holes of the control arm plate and frame. The kits includes new 5/16" hardware to reattach the crossmember. Install a 5/16" flat washer on each of (6) 5/16"-18 x 1 1/4" bolts. THE REAR INNER CROSSMEMBER BOLT WILL NOT BE INSTALLED AT THIS TIME, IT WILL BE INSTALLED WITH THE INSTALLATION OF THE SWAY BAR. Insert the bolts/washers in the (2) front holes and the rear outer holes. With a bolt installed in each hole, install a 5/16" flat washer and 5/16"-18 nylok nut on each of the bolts. Torque the hardware to 25 ft-lbs.

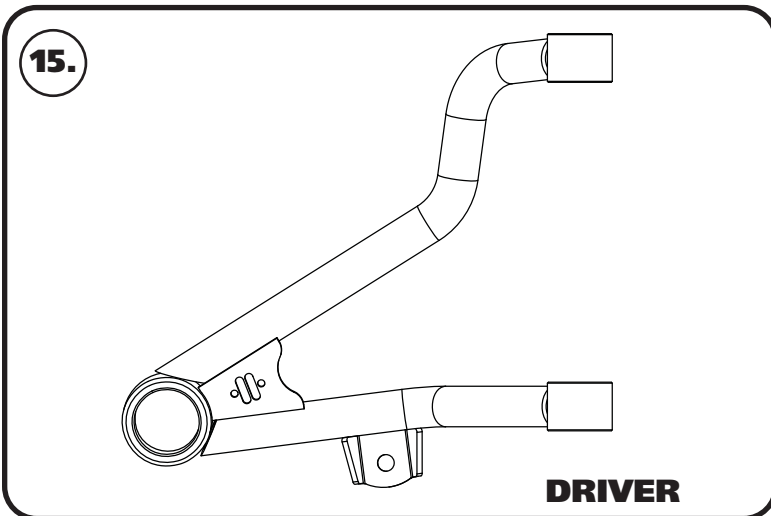

15. Image 15 is of the DRIVER lower arm as viewed from the top.



16. Insert the lower control arm into the mounts. The rear bushing goes into the OEM mount. The front bushing gets installed into the mount on the new lower control arm plate. Align the through hole of the bushing with the slots in the mounts.



Installing Lower Control Arm

17.

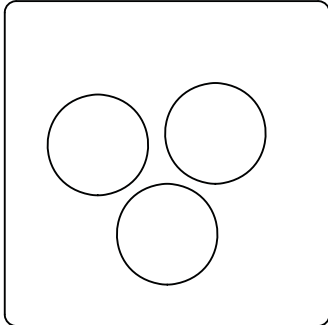

17. Eccentric eliminator plates are included, one must be installed on each side of the frame. Start out with it in the center, make sure both plates are in the same position. The CENTERED position is shown in **Image 17**.

18.



18. Install a 1/2" flat washer on each of (4) 1/2"-20 x 4" hex bolt. Insert the bolt in the eccentric eliminator plate. Install the assembly in the lower control arm mount. Repeat for the 2nd bushing.

19.



19. Install another eccentric eliminator on the threads of the bolt. Make sure the plate is orientated the same as the other plate. Install a 1/2" flat washer and 1/2"-20 nylok nut on the bolt. Repeat for the 2nd bushing. Torque the hardware to 120 ft-lbs.

Repeat **Steps 16-19** on the 2nd control arm.



Installing Upper Control Arm

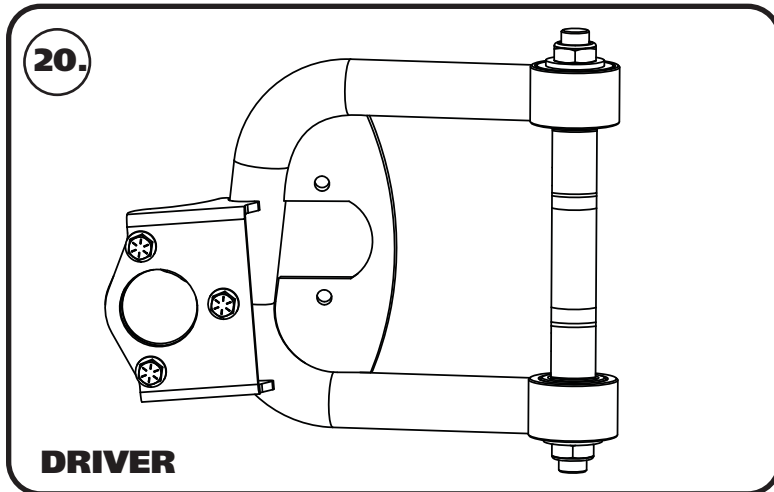

20. Image 20 is of the DRIVER upper arm as viewed from the top.



21. The OEM upper control arm holes need to be drilled out using a 1/2" drill bit.



22a. Steps 22a & 22b illustrate mounting the upper control arm. The upper StrongArm gets bolted to the body using 1/2"-20 x 2 1/2" bolts & flat washers. **The ARROW points to the front of the vehicle.**



Installing Upper Control Arm & Spindle



22b. Hold the arm in place and install the bolt/washers. Install a 1/2" split lock washer and 1/2"-20 nut on the threads of the bolts that are sticking through the shock tower. Torque the hardware to 110 ft-lbs.



23. Install the spindle on the upper ball joint pin. Torque the ball joint castle nut to 50 ft-lbs and tighten to align the cotter pin holes. Install the cotter pin in the ball joint pin hole and bend the ends of the cotter pin to hold it in place. Install the grease zerk supplied with the ball joint.



24. The spindles included in this kit are identical for each side. They are not side specific until the steering arm is attached. Install the spindle on the lower ball joint pin. Torque the ball joint castle nut to 65 ft-lbs and tighten to align the cotter pin holes. Install the cotter pin in the ball joint pin hole and bend the ends of the cotter pin to hold it in place. Install the grease zerk supplied with the ball joint.



Spindle & Centerlink Adapter Installation

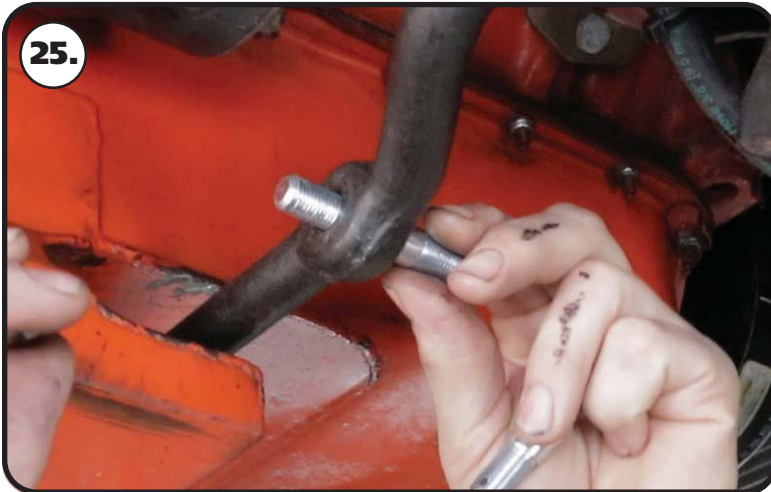

25. The SMALL tapered studs will get installed into the factory centerlink with the taper going into the centerlink, a 7/16" castle nut is used to attach it to the centerlink. The straight shank will point to the front of the car.

Note: It may be necessary to install 7/16" washers under the castle nut to get the cotter pin engaged properly.



26. Torque the nuts to 35 ft-lbs and tighten as needed to align cotter pin. Install cotter pin and bend the ends.

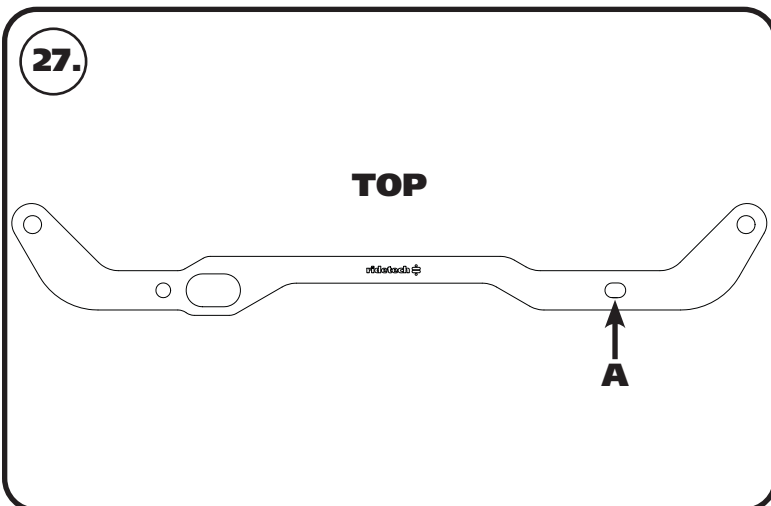

27. The centerlink bracket has one attachment hole [A] that is slotted. This is to accommodate the variations in manufacturing and machining processes, as well as any wear that may have occurred to the original centerlink over time. The slot goes on the passenger side centerlink adapter stud.



Centerlink Adapter Installation



28. Install the draglink adapter on the studs sticking out of the OEM draglink. Install a 1/2"-20 mechanical locking nut on the threads of each stud sticking through the draglink adapter. Torque the nuts to 50 ft-lbs.



29. The studs with the short hex get installed into the centerlink adapter. The short side goes into the adapter attached with the 5/8"-18 thin top lock nut, with the long side of the stud pointing forward.



30. Install the 5/8"-18 **THIN** mechanical locking nut on the threads of the stud sticking through the centerlink adapter and torque to 45 ft-lbs.



Centerlink Adapter, Steering Arm & Stop Installation

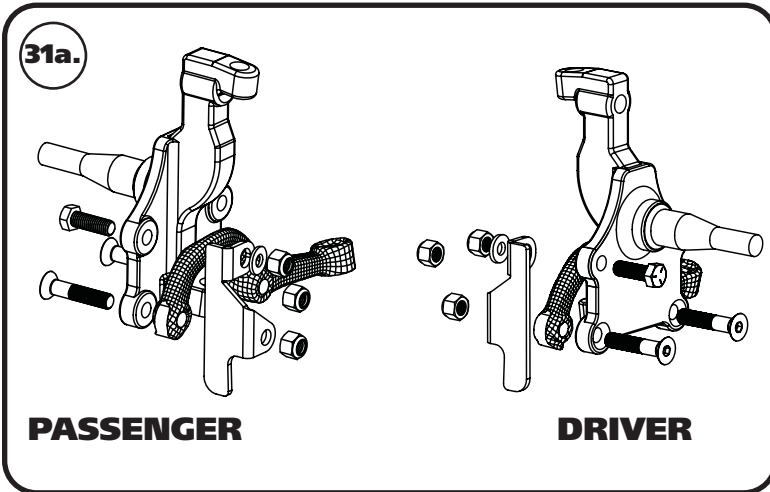

31a. Install the steering arms and steering stops onto the spindle using **Images 31a & 31b** as a reference. The steering arms angle toward the centerlink, and the tie rod mounting holes are to the rear of the car. The steering stops are marked D and P.

The steering arm is attached to the spindle using 1/2"-20 x 2 1/2" flat socket cap bolts and nylok nuts. Torque to 100 ft-lbs.

The upper tab of the steering stop is attached to the spindle using 1/2"-13 x 1 1/2" hex head bolt, 1/2" SAE flat washer, and Nylok. Torque to 75 ftlbs.

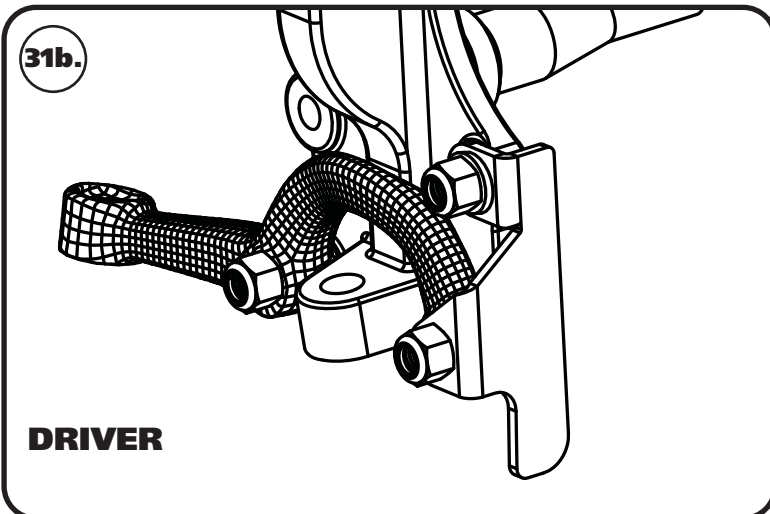

31b. You will notice in **Image 31b**, the bottom hole of the steering stop is mounted on top of the front steering arm mounting hole. The top mounting tab of the steering stop is on the engine side of the spindle.



32. Install the stud with the round flange into the steering arm with the taper going into the steering arm. Torque the nuts to 35 ft-lbs and tighten as needed to align cotter pin hole and install cotter pin.



Tie Rod Assembly & Installation

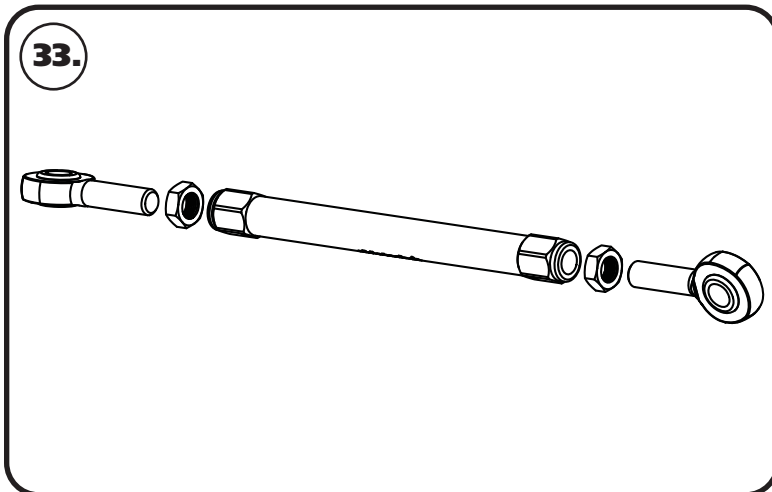

33. The tie rod adjuster has 2 threads in it; 5/8" - 18 RH & 5/8" - 18 LH. The 5/8" - 18 LH thread is marked with a groove on the outside of the adjuster. The tie rod can now be assembled to a center to center length of 11 3/8" to start with, having equal amount of threads on both ends. These aluminum adjusters have a left hand thread on one end and a right hand thread on the other. You should use anti seize when threading the heim ends into the adjuster. **FOR YOUR SAFETY, THE TIE ROD & HEIM NEED A MINIMUM OF 15/16" OF THREAD ENGAGEMENT INTO THE TIE ROD ADJUSTER.**



34. Install one end of the tie rod onto the stud of the centerlink adapter.



35. Install the 5/8" ID x .125" spacer on the stud followed by a 5/8" - 18 mechanical locking nut. Torque to 45 ft-lbs.



Tie Rod Installation



36. Install a 5/8" ID x 3/8" spacer on the steering arm stud, followed by the outer end of the tie rod.



37. Install the 5/8" ID x .125" spacer on the stud followed by a 5/8"-18 mechanical locking nut. Torque to 45 ft-lbs.

Final Tightening & Alignment Specifications

38. Double check that you have tightened all hardware to the proper torque. If you are going to install the Ridetech MuscleBar, now is a good time to do it.

Suggested Alignment Specs:

Camber: Street: -.5 degrees
Caster: Street: +3.0 to + 5.0 degrees
Toe: Street: 1/16" to 1/8" toe in



Torque Specifications

COMPONENTS	TORQUE
LOWER CONTROL ARM MOUNT - 7/16"-14	80 FT-LBS
CROSSMEMBER MOUNTING	25 FT-LBS
FRONT UPPER SHOCK MOUNT TO FRAME	50 FT-LBS
LOWER CONTROL ARM MOUNTING	120 FT-LBS
UPPER BALL JOINT (tighten to align cotter pin hole after torquing)	50 FT-LBS
LOWER BALL JOINT (tighten to align cotter pin hole after torquing)	65 FT-LBS
CENTERLINK STUD NUT - 7/16"-20	35 FT-LBS
CENTERLINK ADAPTER TO STUD - 1/2"-20	50 FT-LBS
INNER TIE ROD STUD - 5/8"-18	45 FT-LBS
STEERING ARM TO SPINDLE	100 FT-LBS
STEERING STOP TO SPINDLE	75 IN-LBS
OUTER TIE ROD STUD - 7/16"-20	35 FT-LBS
INNER & OUTER TIE ROD MOUNTING - 5/8"-18	45 FT-LBS