

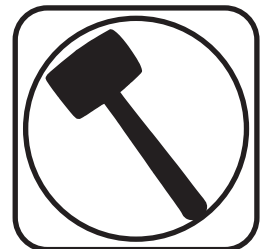

Part # 11257199 -1962-1967 Chevy II Rear Bolt-in 4 Link

Recommended Tools

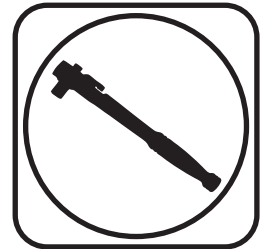
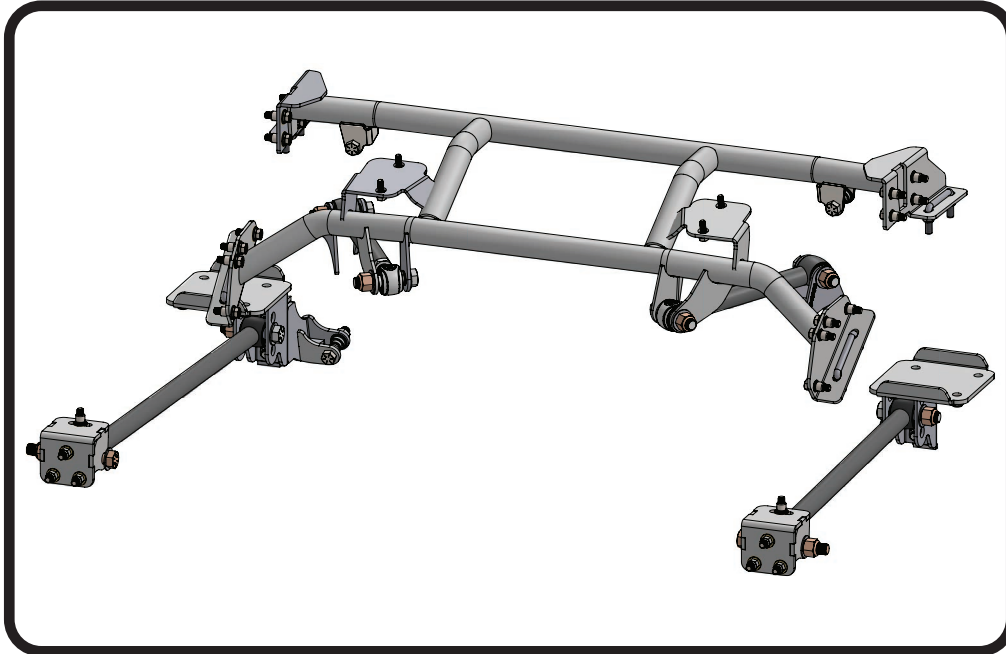

1962-1967 Chevy II Rear Bolt-in 4 Link Installation Instructions

Table of contents

Page 2-4.....	Major Components List, Diagram & Hardware List
Page 5.....	R-Joint Information & Getting Started
Page 6-12.....	Cradle Installation
Page 12-13....	Installing Lower Axle Mount
Page 13.....	Lower Shock Mount Installation
Page 14-15....	Front Lower Bar Mount Installation
Page 16-17....	Lower Bar & Shock Stud Installation
Page 18.....	Setting Pinion Angle
Page 19.....	Upper Bar Axle Tab Installation
Page 20-21....	Installing Axle Tabs & Upper Bars
Page 22-23....	Installing ShockWaves/CoilOvers





Major ComponentsIn the box

Item #	Part #	Description	QTY
1	90003319	4-Link Rear Cradle	1
2	90003332	Lower Frame Bracket	2
3	90003333	Rear Lower Shock Mount-Driver	1
4	90003334	Rear Lower Shock Mount-Passenger	1
5	90003347	Rear Lower Bar Axle-Driver	1
6	90003348	Rear Lower Bar Axle-Passenger	1
7	90000144	Upper Bar Axle Tabs	4
8	70015642	R-Joint Spacers - 5/8" ID x 1.620" W	2
9	70013334	R-Joint Spacers - 5/8" ID x .620" W	14
10	90002285	Square U-Bolts	8
11	90002819	4 Link Lower Bar - 25.0625" center to center	2
12	90002855	4 Link Upper Bar - 10.00" center to center set length	2
13	90001318	RH R-Joint Threaded Housing End (installed in upper bars)	2
14	99752004	3/4"-16 Jam Nut (installed on upper bar R-Joint)	2
	70010694	Bar Tab Setting Jig	2
R-Joint Components - (Installed in bar ends)			
	70013279	Retaining Ring	6
	70013280	Wavo Wave Spring	6
	70013275	R-Joint Center Ball	6
	70013276	R-Joint Composite Center Ball Cage	6



Hardware ListIn the box (Kit# 99010183)

The 4-Link Kit is supplied with a hardware kit. This hardware kit contains individual bags for the different parts of the installation. The bags are labeled to help determine the correct hardware for the installation of the specific parts of the kit. The instructions will aid you in selecting the correct hardware during the installation. The kit includes Riv-nuts and installation tool for installation of the rear cradle. Refer to Page 9 for the correct installation procedure of the Riv-nuts.

Item #	Cradle To Frame		QTY
not shown	85000007	17/32" DRILL BIT FOR RIV-NUTS	1
15	99371005	3/8-16 X 1.25" HEX BOLT GR8	16
16	99372007	3/8-16 RIV-NUT	16
17	99373006	3/8" SPLIT LOCK WASHER GR8	16
18	99373002	3/8" SAE FLAT WASHER GR8	16
	Lower Frame Mount		
15	99371005	3/8-16 X 1.25" HEX BOLT GR8	8
16	99372007	3/8-16 RIV-NUT	2
17	99373006	3/8" SPLIT LOCK WASHER GR8	2
18	99373002	3/8" SAE FLAT WASHER GR8	16
19	99372001	3/8-16 NYLON LOCKNUT GR8	6
	Cradle U-Bolts		
18	99373002	3/8" SAE FLAT WASHER GR8	16
19	99372001	3/8-16 NYLON LOCKNUT GR8	16
	Cradle To Shock Mounts		
20	99311030	5/16-18 x 1" HEX BOLT GR8	4
21	99313006	5/16" USS FLAT WASHER GR8	4
22	99313005	5/16" SPLIT LOCKWASHER GR8	4
	Shock To Cradle		
23	99501010	1/2-20 X 2.25" HEX BOLT GR8	2
24	99502003	1/2-20 THIN NYLOK JAM NUT	2
	Shock To Lower Mount		
25	99501021	1/2-20 X 2.75" HEX BOLT GR8	2
26	99502002	1/2-20 NYLON LOCKNUT GR8	2
	Shock Mount To Lower Axle Mount		
26	99502002	1/2-20 NYLON LOCKNUT GR8	4
27	99501008	1/2-20 X 1.50" HEX BOLT GR8	4
28	99503014	1/2" SAE FLAT WASHER GR8	8
	Upper & Lower Control Arms		
29	99621018	5/8-18 X 3.25" HEX BOLT GR8	6
30	99621007	5/8-18 X 5" HEX BOLT GR8	2
31	99622001	5/8-18 NYLON LOCKNUT GR8	8
32	99623001	5/8" SAE FLAT WASHER GR8	16
	Lower Axle Mount		
33	99432007	7/16-20 NYLON LOCK NUT GR8	8



R-Joint Information

R-JOINT SPACER INSTALLATION

Install the Spacers by inserting the SMALL side of the SPACER into the Center Pivot Ball. Push them in until they bottom out and stop.

LOWER FRONT R-JOINT

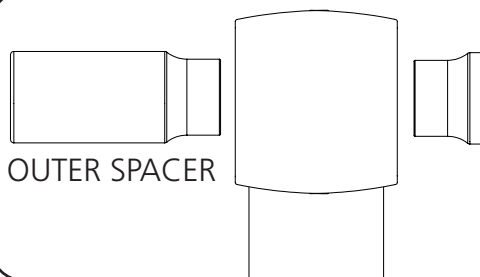

OUTER SPACER

ALL OTHER R-JOINTS

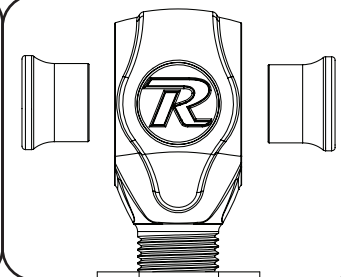

New R-Joints will be quite stiff (75-90 in/lbs breakaway torque) until they "break in" after a few miles of use. After the break in period they will move much more freely. Because the composite bearing race contains self lubricating ingredients, no additional lubrication is needed or desired. Any additional lubrication will only serve to attract more dirt and debris to the R-Joint and actually shorten its life.

Getting Started.....

Congratulations on your purchase of the Ridetech Rear 4-link System. This system has been designed to give your Chevy II excellent handling along with a lifetime of enjoyment. This system provides tunability, replaces the leaf springs, and allows the 4-Link to locate the rearend and the CoilOvers/ShockWaves to support the car.

Note: This system is designed for use with the Ridetech Shockwaves or CoilOvers. **The factory shocks and springs will not fit this setup.**

1. Raise the vehicle to a safe and comfortable working height. Use jack stands to support the vehicle with the suspension hanging freely.
2. Support the axle and remove the leaf springs, shocks and tail pipes. Refer to the factory service manual for proper disassembly procedures. The rear seat will also need to be removed.



3. Remove the emergency brake cable hold down from the pinion stop.



Cradle Installation



4. Remove the fuel line from the hold down that is beside the passenger upper shock mount.

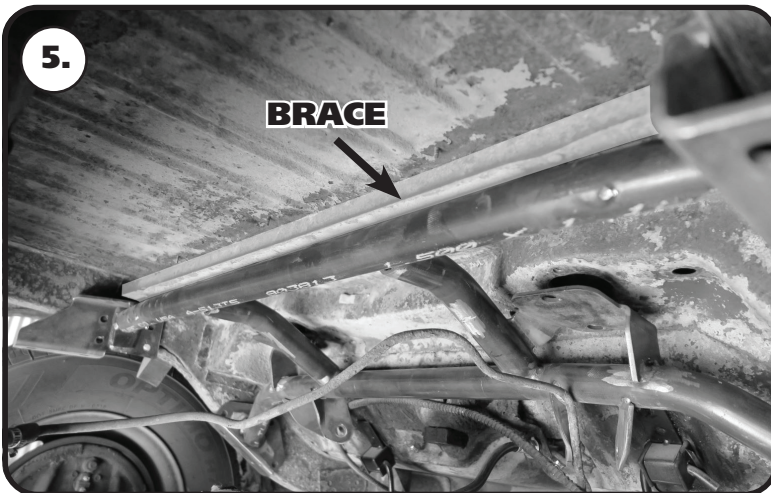

5. **WAGON ONLY!** The wagons have a brace on the rear floor pan that will need to be removed. This brace is right above the rear cradle tube. The tube will support the floor pan.



6. Use a jack under the rear crossmember of the cradle to help hold it up in place.



Cradle Installation



7. Use a pry tool to help align the cradle with the OEM shock mounting holes..



8. Install a 5/16" SAE flat washer and 5/16" split lock washer on each of (4) 5/16"-18 x 1" bolts. Thread each bolt into the OEM shock mounting holes. Tighten the (4) bolts that attach the cradle to the OEM shock mounting holes.



9. Use the frame plates as a template to drill the holes in the bottom of the frame rails. Use a 7/16" drill bit to drill the holes. Drill the slotted hole to the outside of the slot.



Cradle Installation



10. Feed one end of the u-bolt through the round hole of the pair of holes, using the other end of the u-bolt as a handle. You need to get the end of the u-bolt that you are using as a handle fed in until it is past the 90 degree bend to be able to drop the other end through the drilled hole. If the u-bolt will not line up with the drilled holes, it may be necessary to slot the frame hole in the slotted hole of the frame mount.

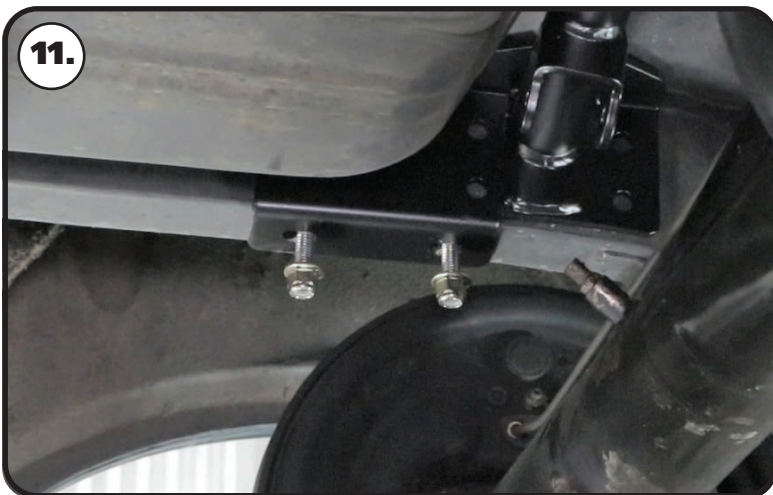

11. Install (1) 3/8" Flat washer and (1) 3/8"-16 nylok nut onto each stud sticking through the cradle. Do not tighten them until all washers and nuts are installed. Tighten each leg of the u-bolt evenly. Torque to 30 ftlbs. Do this for all (4) u-bolts..



12. Mark or center punch the holes of the vertical surfaces of the frame mounts. These holes use Riv-nuts to bolt the cradle to the frame. The holes need to be centered as much as possible. Mark or center punch the holes for the driver and passenger frame rails.



Riv-nut® Installation & Specs

1. Drill Hole in Frame using the SUPPLIED DRILL BIT keeping the Drill square with the metal.
2. We recommend installing (2) 3/8" Flat Washers between the bolt head and the lower anvil of the installation tool. Thread a Riv-nut® onto the supplied Tool. Thread the Riv-nut all the way onto the Tool until it stops.
3. Insert the Tool and Riv-nut® into the drilled hole 90° to the Frame Rail.
4. The Tool requires (2) 9/16" Wrenches to use. A Ratchet can be used on the top of the Tool.

KEEP THE TOOL AND RIV-NUT 90° TO THE SURFACE WHILE TIGHTENING

5. Put a 9/16" Wrench on the Lower Hex of the tool. Use a Wrench or Ratchet on the Top hex to Tighten.
6. Hold the Wrench in one position and turn the TOP HEX CLOCKWISE to engage the Riv-nut®. Keep Turning the TOP WRENCH until you feel a positive stop and you can't turn the TOP WRENCH anymore.
7. Break the Tool loose by turning the TOP HEX counterclockwise and thread the Tool out of the Riv-nut®.

THE DATA BELOW ILLUSTRATES THE STRENGTH OF THE RIV-NUT®

RIVNUT® Fastener Engineering Data

Upset Load (lbs.)		
RIVNUT * Size	Steel	
	Min. Grip	Max. Grip
3/8-16	4965	5325

Fig. 1

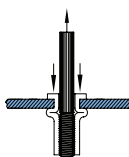

Ultimate thread strength (lbs.)		
RIVNUT * Size	Steel	
	Min. Grip	Max. Grip
3/8-16	11500	10450

Fig. 2

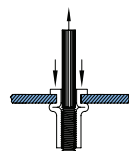

Ultimate tensile strength (lbs.)	
RIVNUT * Size	Steel
3/8-16	3900

Fig. 3

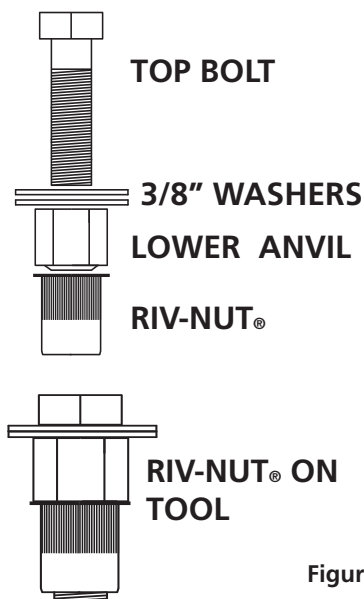
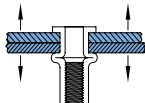

Figure 2

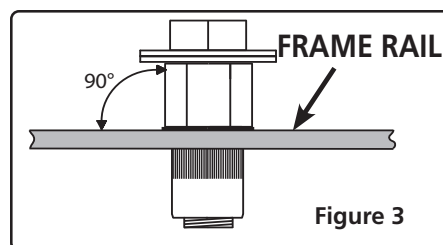

Figure 3

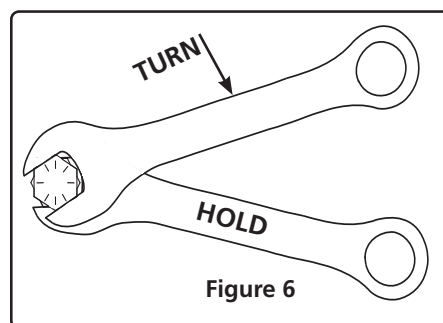

Figure 6

**Single Shear Strength 3/8" Grade 5 Bolt
3,975.8 lbs**



Cradle Installation



13. The cradle will need to be removed to allow for drilling of the holes and installing the riv-nuts



14. The holes for the Riv-nuts NEED to be drilled with the supplied 17/32" drill bit. We suggest drilling the holes with a smaller drill bit first to make it easier to drill with the 17/32" drill bit. Drill all (16) holes in the sides of the frame rails.



15. Install the Riv-nuts in the sides of the frame rails. **Refer to the Riv-nut installation instructions on PAGE 9 for proper Riv-nut installation.** Image 15 illustrates a Riv-nut being installed. Install all (16) Riv-nuts in the frame rails.



Cradle Installation



16. Image 16 shows the Riv-nuts installed in the passenger side frame rail.



17. Reinstall the cradle in the car. Reinstall the 5/16" hardware that attaches the cradle to the OEM shock mounting holes. Torque to 9 ft-lbs.



18. Reinstall the 3/8" hardware on the u-bolts. Do not tighten them until all washers and nuts are installed. Tighten each leg of the u-bolt evenly. Torque to 30 ftlbs. Do this for all (4) u-bolts.



Cradle & Axle Mount Installation



19. Install a 3/8" split lock washer, and a 3/8" flat washer on each of (16) 3/8"-16 x 1 1/4" hex bolts. Thread a bolt/washer in to each of the Riv-nuts installed in the frame rails. Make sure the bottom tabs are against the frame rails before tightening the bolts. Torque the bolts to 23 ftlbs.

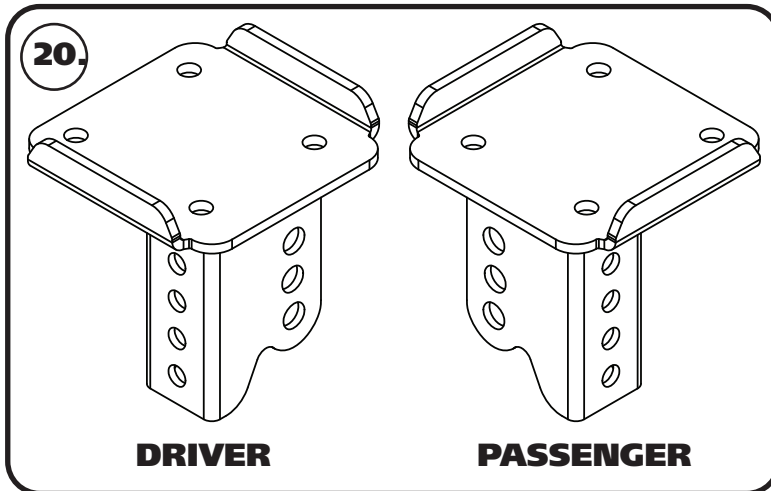

20. The lower axle mounts are side specific. The bar/shock mount is offset to the inside to help get more wheel and tire clearance.



21. The lower axle bracket will be fastened to the leaf spring pad using the factory T-bolts/U-bolts. The bar mount is offset to the inside of the car to provide more wheel and tire clearance.

Image 21 shows the Driver side.



Axle & Shock Mount Installation



22. New 7/16" nyloks are supplied in the hardware kit. Torque the nuts to 55 ftlbs.



23. The lower shock mount attaches to the lower axle mount. The shock mounting ears will be to the center of the car. The shock mount has (2) mounting holes with the axle mount having (4) holes. The lower mounting hole of each will need to be lined up. Install a 1/2" flat washer on each of (2) 1/2"-20 x 1 1/2" bolts. With the lower mounting holes aligned, insert a bolt/washer in each mounting hole.

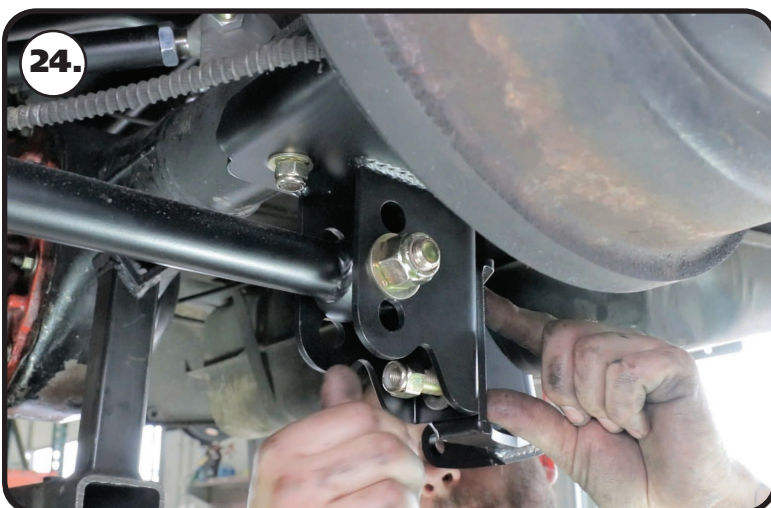

24. Install a 1/2" flat washer and 1/2"-20 nylok nut on the threads of each bolt. Torque to 90 ft-lbs.



Front Lower Bar Mount Installation

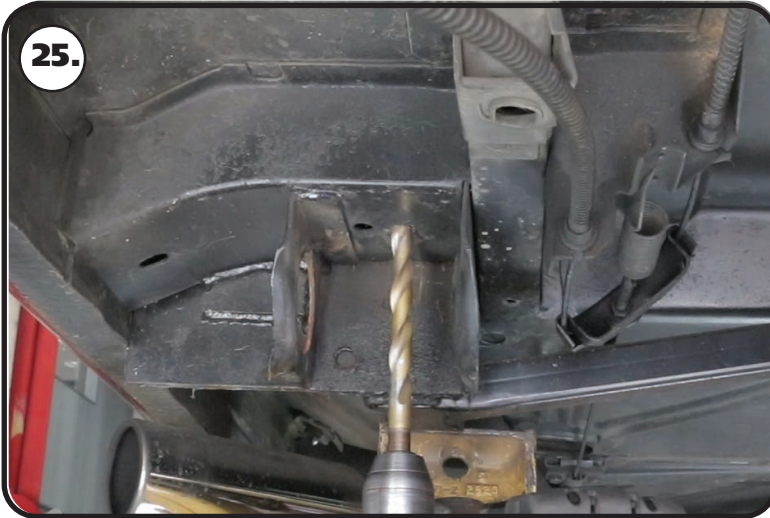

25. Steps 25 - 29 cover the installation of the front lower bar mount. We recommend reading through the steps before trying to do the installation. The front of the mount has (2) mounting holes and a slot. This surface will get bolted to the front of the OEM leaf spring mount. Using the supplied 17/32" drill bit, drill out the INNER hole that will be above the bar mount.



26. Install a Riv-nut in the inner hole that was drilled out in the previous step. **Refer to the Riv-nut installation instructions on PAGE 9 for proper Riv-nut installation.**



27. The OEM inner leaf spring mounting hole will need to be drilled out to at least 5/8". **After drilling the hole out, hold the new mount in position to check alignment. It may be necessary to drill the inner OEM leaf spring bolt hole out if it doesn't line up with the new mount.** We used a unibit to drill the OEM hole out.



Front Lower Bar Mount Installation

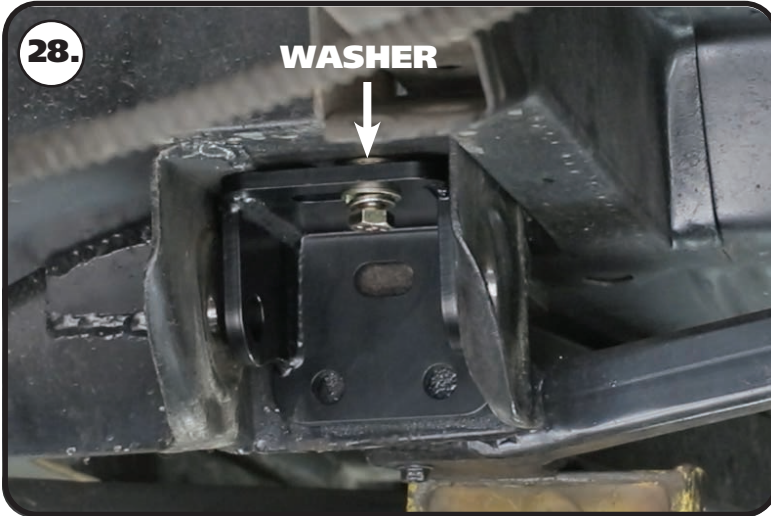

28. The mount will be bolted to the Riv-nut using a 3/8" split lock washer, 3/8" flat washer, & 3/8"-16 x 1 1/4" bolt. A 3/8" flat washer will need to be installed on the top side of the mount in between the mount and the sheet metal of the car. Make sure the mount is sitting against the front of the OEM leaf spring mount and lightly tighten the bolt.

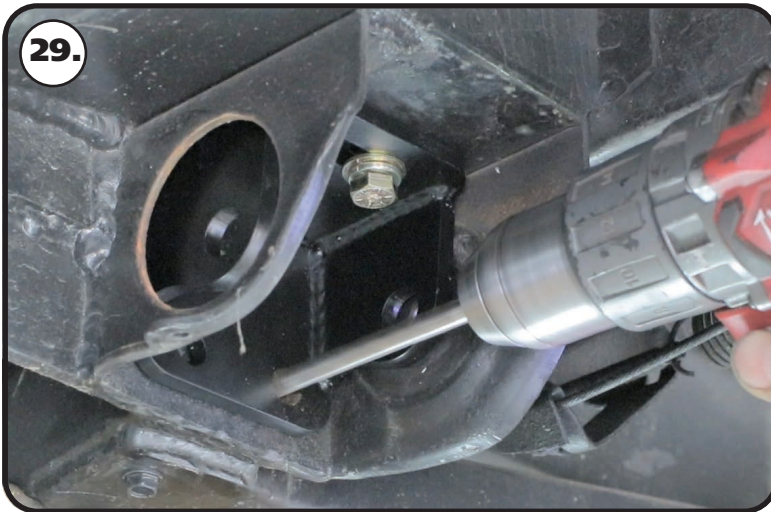

29. Drill the (3) holes in the front of the OEM leaf spring mount using the mount as a drill guide. Use a 3/8" drill bit to drill the holes. The upper slotted hole needs to be drilled in the center of the slot.



30. Install a 3/8" flat washer on each of (3) 3/8"-16 x 1 1/4" bolts. Insert the bolts through the mount and drilled holes. Install a 3/8" flat washer and 3/8"-16 nylok nut on the threads of each bolt. Torque the bolts to 45 ft-lbs. Torque the top bolt to 23 ft-lbs.



Lower Bar Installation



31. The R-joint setup is designed to be offset to the inside of the car. The wider spacer is used on the outside with a narrow spacer on the inside. This will offset the bar to the inside of the car for better wheel and tire clearance. Insert the R-joint and spacers into the front lower bar mount. Align the through hole of the r-joint/spacers with the mounting holes of the lower mount.



32. The front of the Lower Bar is attached with 5/8"-18 x 5" Hex Bolt. Install a 5/8" flat washer on the 5/8"-18 x 5" bolts supplied in the hardware kit. With the R-joint through holes aligned with the OEM leaf spring hole, insert the 5/8" bolt/washer through the aligned mounting holes. Install a 1/2" flat washer and 1/2"-13 nylok nut on the threads of the bolt. Tighten enough to eliminate any gaps in the front mount.



33. Install a 5/8" flat washer and 5/8"-18 nylok nut on the threads of the bolt. Tighten enough to eliminate any gaps in the front mount.



Lower Bar Installation



34. The Axle end of the bar gets a NARROW(70013334) R-Joint spacer inserted into each side of the R-Joint. Align the R-joint with the **CENTER** hole of the axle mount.

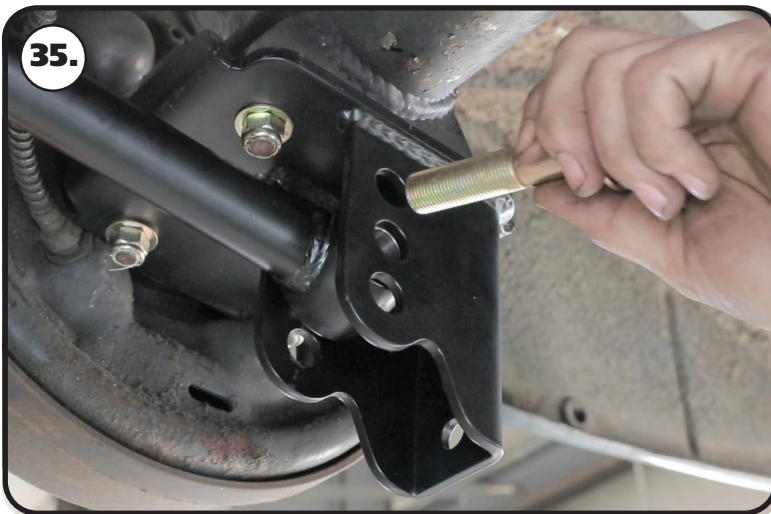

35. Install a 5/8" flat washer on a 5/8"-16 x 3" hex bolt. Insert the bolt/washer through the axle mount/bar. Install a 5/8" flat washer and 5/8"-16 thin nylok nut on the threads of the bolt. Do this for both sides. Tighten the bolt/nut enough to eliminate any gaps.



36. Install a 5/8" flat washer and 5/8"-16 nylok nut on the threads of the bolt. Do this for both sides. Tighten the bolt/nut enough to eliminate any gaps.



Setting Pinion Angle

READ PAGES 18 & 19 ON SETTING PINION ANGLES, UPPER BAR TAB JIG INSTALLATION, & SETTING RIDE HEIGHT.

How do you set the pinion angle? On a single-piece shaft you want to set it up where a line drawn through the center of the engine crankshaft or output shaft of the transmission and a line drawn through the center of the pinion are parallel to each other but not the same line.

Your transmission angle should be around 3 degrees down in the rear. If it is more or less than 3 degrees, you might want to consider changing it. Too little angle on the transmission reduces the amount of oil getting to the rear bushing. Too much transmission angle will increase the working angles of the u-joints which will increase the wear. With the transmission at 3 degrees down in the rear, you will want to set the pinion 3 degrees up in the front.

A simple way to do this is to place a digital angle finder or dial level on the front face of the lower engine pulley or harmonic balancer. This will give you a reading that is 90 degrees to the crank or output shaft unless you have real problems with your balancer. At the other end, you can place the same level or angle finder against the front face of the pinion yoke that is also at 90 degrees to the centerline. If you rotate the yoke up or down so both angles match, you have perfect alignment.

Road testing will tell you if you have it right. If you accelerate and you get or increase a vibration, then the pinion yoke is too HIGH. Rotate it downward in small increments of a degree or two until the problem goes away. If you get or increase a vibration when decelerating, then the pinion yoke is too LOW. Rotate it upward to correct it.

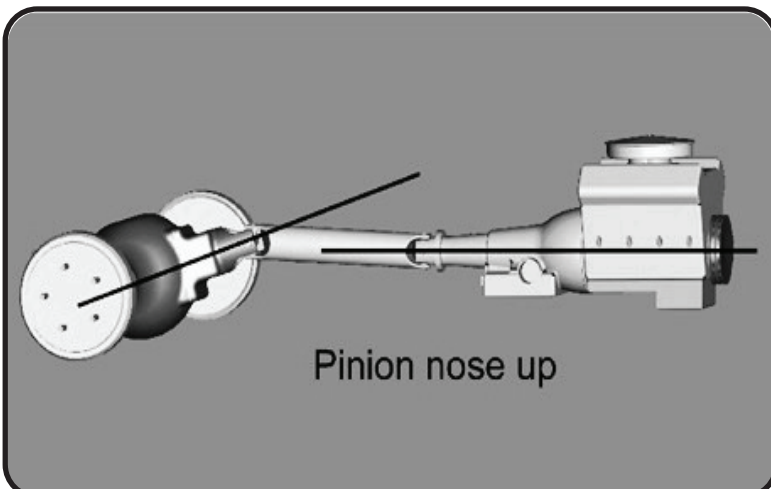
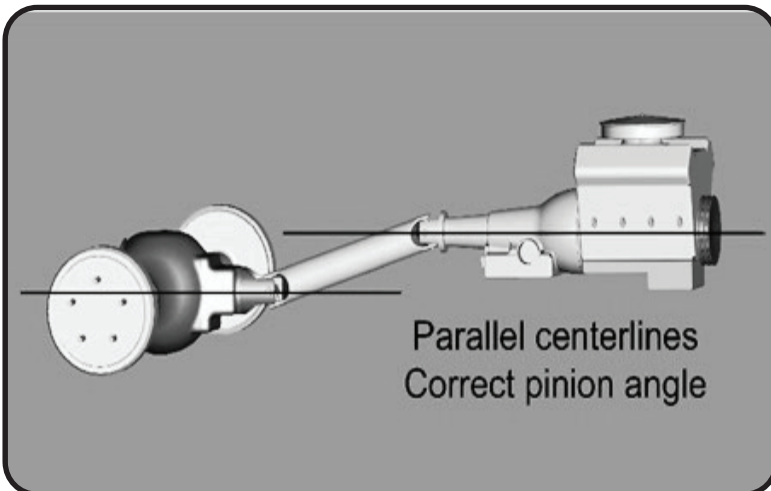
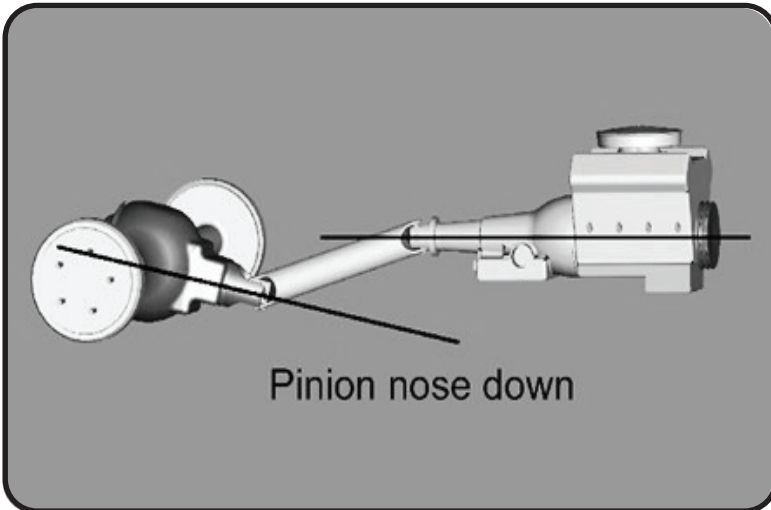



Upper Bar Tab Installation Jig

Upper Bar Installation Jig

- This jig has been supplied to aid in the installation of the upper 4 link bar. It can be temporarily used to properly align, locate and weld the tabs onto the axle. It will also ensure that the mounting bolts are parallel to each other.
- Follow the diagram below to set the jig to the same length as the upper bar, use the 3/8" x 3/4" bolt and nuts to set the length.
- Position the axle at ride height. Center the axle left to right between the quarter panels. Set pinion angle.
- Bolt one end of the jig to the cradle using a 5/8" x 3" bolt.
- Using another 5/8" x 3" bolt, fasten the axle tabs to the other end. The tabs will get bolted to the jig inner tab having the long side forward. The outer tab will have the long side rearward. The tabs must be bolted to the outside of the jig.
- Swing the bar down letting the tabs rest onto the axle.
- Check pinion angle, ride height and axle center. Tack-weld the tabs in place.
- Remove jig and install upper bar.
- Repeat this process for the other side.
- Recheck pinion angle, ride height and axle center. (Sound familiar?)
- After the tabs have been tack welded on both sides, remove the setting jig. Let the axle drop down for better access to the tabs. Lay 1" welds on the inside and outside of the tabs. Skip around from one side to the other to avoid overheating the tube.

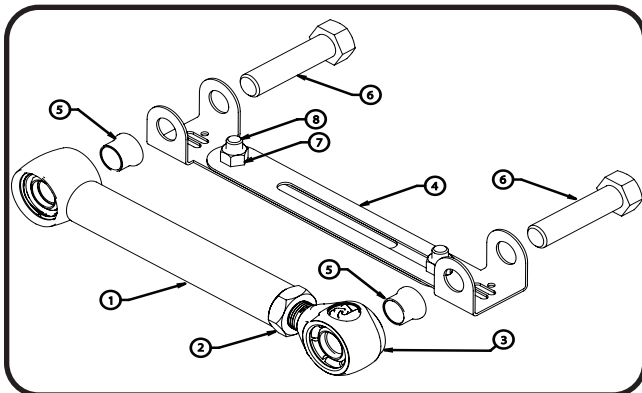

Item#	Description
1	Upper Bar
2	3/4"-16 Jam Nut
3	R-Joint End
4	Alignment Jig
5	Aluminum Spacer
6	5/8" x 3" Bolt
7	3/8"-16 Nut
8	3/8"-16 x 3/4" Bolt



Installing Axle Tabs & Upper Bars

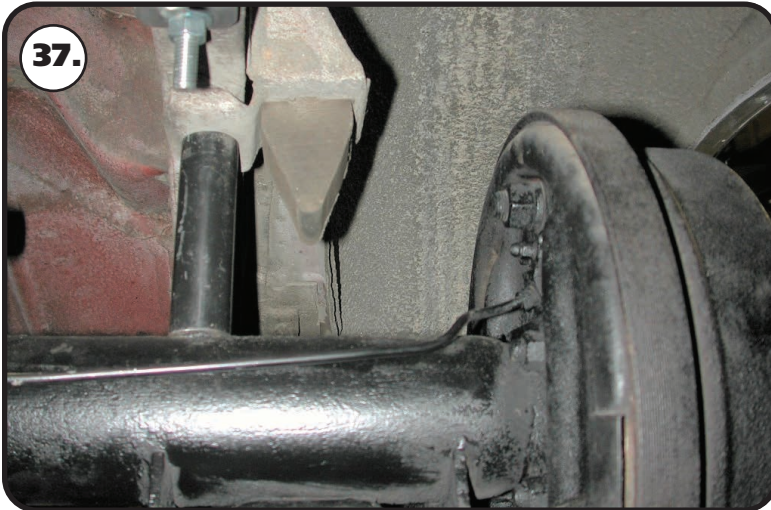

37. Before welding the tabs you must center the axle and set the pinion angle. This must be done at ride height. Raise the axle until the is 14 1/2" from center eye to center eye on the Shockwave mounts, this is ride height. One trick that we use to maintain the settings are to tack weld a 4" spacer between the axle and the frame.



38. Insert NARROW(70013334) spacers into each side of the R-Joints of the Upper Bar.



39. Align the R-joint with the upper bar mounts in the cradle.



Installing Axle Tabs & Upper Bars



40. Install a 5/8" flat washer on a 5/8"-16 x 3 1/4" hex bolt. Insert the bolt/washer through the upper bar mount/bar. Install a 5/8" flat washer and 5/8"-16 nylok nut on the threads of the bolt. Do this for both sides. Tighten the bolt/nut enough to eliminate any gaps. Do this for both upper bars.



41. When the tabs cool down, insert NARROW(70013334) spacers into each side of the R-Joints of the Upper Bar. Align the R-joint with the upper bar mounts on the axle.

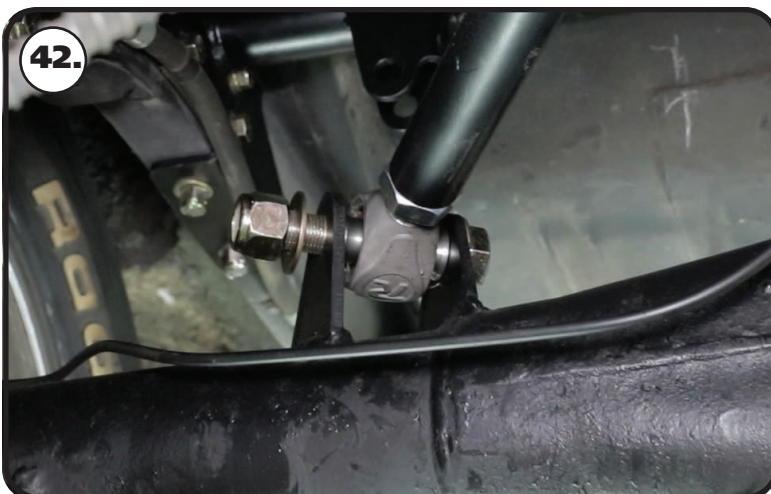

42. Install a 5/8" flat washer on a 5/8"-16 x 3 1/4" hex bolt. Insert the bolt/washer through the upper bar mount/bar. Install a 5/8" flat washer and 5/8"-16 nylok nut on the threads of the bolt. Do this for both sides. Tighten the bolt/nut enough to eliminate any gaps. Do this for both upper bars.

Note: Steps 36 & 37 cover the CoilOver/ ShockWave installation. CoilOvers can be installed with the shock body up or down. ShockWaves must be installed with the shock body down.



Installing Shockwaves/Coilovers



43. Ridetech CoilOvers or ShockWaves require a spacer on each side of the bearing. The upper shock uses a 1/2" ID spacer that is 3/8" long (90002043). The overall width with a spacer on each side will be 1 1/4". **The small side of the spacer goes into the shock bearing.** Insert the Shock with the 1/2" ID Spacers into the shock mount.



44. Line up the holes in the mount with the spacers and shock bearing. Insert a 1/2"-20 x 2 1/4" hex bolt into the lined up holes. Install a 1/2"-20 Thin Jam Nylok Nut. Torque to 22 ftlbs

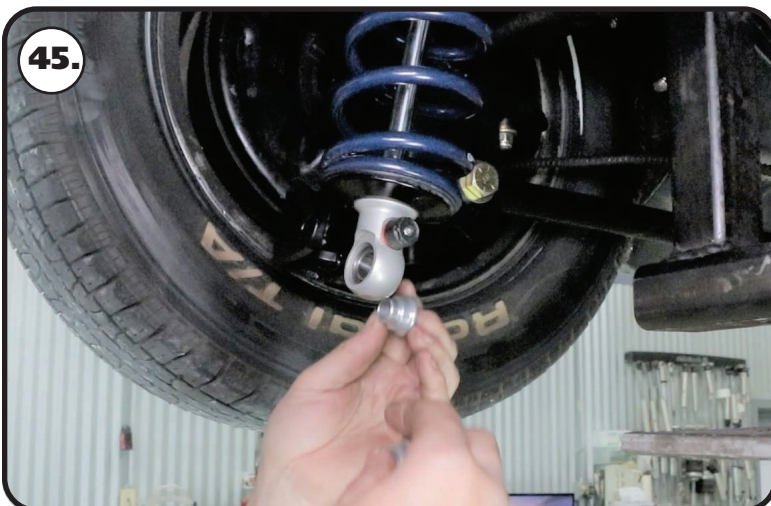

45. Ridetech CoilOvers or ShockWaves require a spacer on each side of the bearing. The lower shock uses a 1/2" ID spacer that is 3/8" long (90002043). The overall width with a spacer on each side will be 1 1/4". **The small side of the spacer goes into the shock bearing.** Insert the shock with the 1/2" ID spacers into the shock mount.



Installing Shockwaves/Coilovers



46. Line up the holes in the mount with the spacers and shock bearing. Insert a 1/2-20 x 2 3/4" hex bolt into the lined up holes. Install a 1/2"-20 Nylok Nut. Torque to 22 ftlbs.

NOTE: BEFORE INSTALLING SHOCKWAVES
The correct pinion angle must be set first. Failure to do so could result in damage to the ShockWave by the bag rubbing the Lower Axle Mount.

Note: If installing Shockwaves and you want to locate the air fitting in a different location, the air spring assembly can be rotated on the shock by grabbing the shock and air spring assembly by hand and spinning the shock in the air spring assembly.

The designed ride height of the CoilOver/Shockwave is 14 1/2" center to center.

Double check all the hardware to ensure it is tight.

Torque Specifications

COMPONENTS	TORQUE
CRADLE U-BOLTS	30 FT-LBS
CRADLE TO OEM SHOCK MOUNTS	9 FT-LBS
CRADLE RIV-NUT HARDWARE	23 FT-LBS
LOWER AXLE MOUNT TO AXLE	55 FT-LBS
FRONT LOWER BAR MOUNT RIV-NUT HARDWARE	23 FT-LBS
FRONT LOWER BAR MOUNT 3/8" NYLOK NUT	45 FT-LBS
4-LINK BAR HARDWARE	TIGHTEN TO ELIMINATE GAPS
SHOCK MOUNTING HARDWARE	22 FT-LBS