



350 S. St. Charles St. Jasper, In. 47546

Ph. 812.482.2932 Fax 812.634.6632

www.ridetech.com

Part #11173011

70-81 GM "F" Body Front TQ Series ShockWaves

For Use w/ Lower StrongArms

ShockWave Assembly:

2	24090199	6.5" Double Convoluted Bellow Assembly
2	24339999	3.6" stroke TQ Series shock
2	90001994	.625" I.D. bearing
4	90001995	Bearing snap ring
2	90009989	Tall Delrin stud top – 2.75"
2	70008913	Locking Ring

Components:

2	90002313	Tall Delrin stud top base – 2.75"
2	90001902	Aluminum cap for Delrin ball
2	90001903	Delrin ball upper half
2	90001904	Delrin ball lower half
4	90002221	Reservoir Mount
1	85000003	4mm Allen Wrench

Hardware:

2	99562003	9/16" SAE jam nut	Stud top hardware
12	99050000	4mm Socket Head Screw	Reservoir Mount

TAMPERING WITH THE FITTING ASSEMBLY WILL VOID THE WARRANTY

SHOCKwave®

Installation Instructions



1. The frame pocket must be trimmed to ensure that the air spring does not rub against the frame. The coil spring retaining “fingers” must also be trimmed.

Note: The inflated diameter of this air spring is approximately 6”.

2. The top of the Shockwave will attach to the factory shock hole. The factory hole will need to be drilled to $\frac{3}{4}$ ”. For assembly see diagram on following page.

TIGHTENING THE TOP 9/16”-18 NUT: SNUG THE NUT DOWN AGAINST THE TOP CAP. YOU NEED TO BE ABLE TO ARTICULATE THE SHOCK BY HAND. WE TORQUE THE NUT TO 80 INLBS USING A 7/8” CROWS FOOT WRENCH ON A TORQUE WRENCH.

3. Fasten the Shockwave to the lower arm w/ the spacer and bolts provided w/ the lower arms.

4. Double check air spring clearance throughout full suspension travel.
Allowing the bellow to rub will result in failure and is not a warrantable situation.

5. The best ride quality will occur around 50-60% suspension travel, depending on vehicle weight this typically occurs around 90-100 psi.

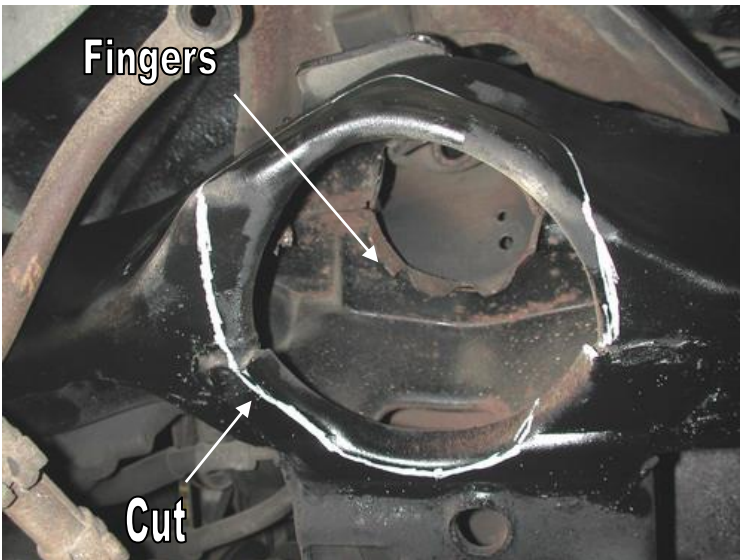

1. Stud top aluminum base
2. Delrin ball lower half
3. Delrin ball upper half
4. Aluminum cap
5. 9/16" SAE Nylok jam nut
6. Threaded stud (screwed onto shock shaft)
7. Rebound adjusting knob
8. Screw

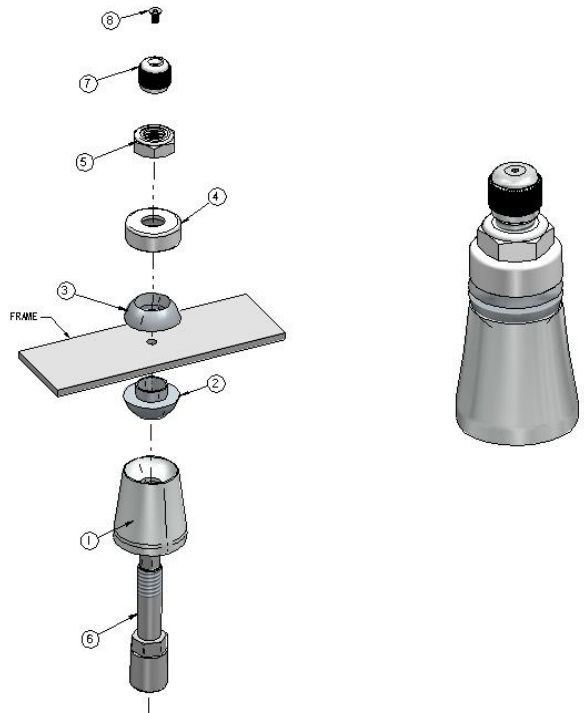

SHOCKWave®

The care and feeding of your new ShockWaves

1. Although the ShockWave has an internal bumpstop, **DO NOT DRIVE THE VEHICLE DEFLATED RESTING ON THIS BUMPSTOP. DAMAGE WILL RESULT.** The internal bumpstop will be damaged, the shock bushings will be damaged, and the vehicle shock mounting points may be damaged to the point of failure. **This is a non warrantable situation.**
2. Do not drive the vehicle overinflated or "topped out". Over a period of time the shock valving will be damaged, possibly to the point of failure. **This is a non warrantable situation!** If you need to raise your vehicle higher than the ShockWave allows, you will need a longer unit.
3. The ShockWave is designed to give a great ride quality and to raise and lower the vehicle. **IT IS NOT MADE TO HOP OR JUMP!** If you want to hop or jump, hydraulics are a better choice. This abuse will result in bent piston rods, broken shock mounts, and destroyed bushings. **This is a non warrantable situation.**
4. Do not let the ShockWave bellows rub on anything. Failure will result. **This is a non warrantable situation.**
5. The ShockWave product has been field tested on numerous vehicles as well as subjected to many different stress tests to ensure that there are no leakage or durability problems. Failures have been nearly nonexistent unless abused as described above. If the Shockwave units are installed properly and are not abused, they will last many, many years. **ShockWave units that are returned with broken mounts, bent piston rods, destroyed bumpstops or bushings, or abrasions on the bellows will not be warrantied.**