



350 S. St. Charles St. Jasper, In. 47546  
Ph. 812.482.2932 Fax 812.634.6632  
[www.ridetech.com](http://www.ridetech.com)

**Part # 11163511**  
**67-69 GM "F" Body TQ Series Front CoilOvers**  
For Use w/ StrongArms & RideTech Spindles

**Shock Assembly:**

- |   |          |                                    |
|---|----------|------------------------------------|
| 2 | 24339999 | 3.6" stroke TQ Series shock        |
| 2 | 90009989 | 2.75" adjustable threaded stud top |
| 2 | 90001994 | .625" I.D. bearing                 |
| 4 | 90001995 | Bearing snap ring                  |

**Components:**

- |   |          |                                    |
|---|----------|------------------------------------|
| 2 | 59080700 | Coil spring – 8" long / 700 # rate |
| 2 | 90002313 | 2.75" stud top base                |
| 2 | 90002222 | Spring retainer kit                |
| 2 | 90001902 | Aluminum cap for Delrin ball       |
| 2 | 90001903 | Delrin ball upper half             |
| 2 | 90001904 | Delrin ball lower half             |
| 4 | 70010828 | Delrin Spring Washer               |
| 4 | 90002221 | Reservoir Mount                    |
| 1 | 85000003 | 4mm Allen Wrench                   |

**Hardware:**

- |    |          |                         |                   |
|----|----------|-------------------------|-------------------|
| 2  | 99562003 | 9/16" SAE Nylok jam nut | Stud top hardware |
| 12 | 99050000 | 4mm Socket Head Screw   | Reservoir Mount   |

# COILOver

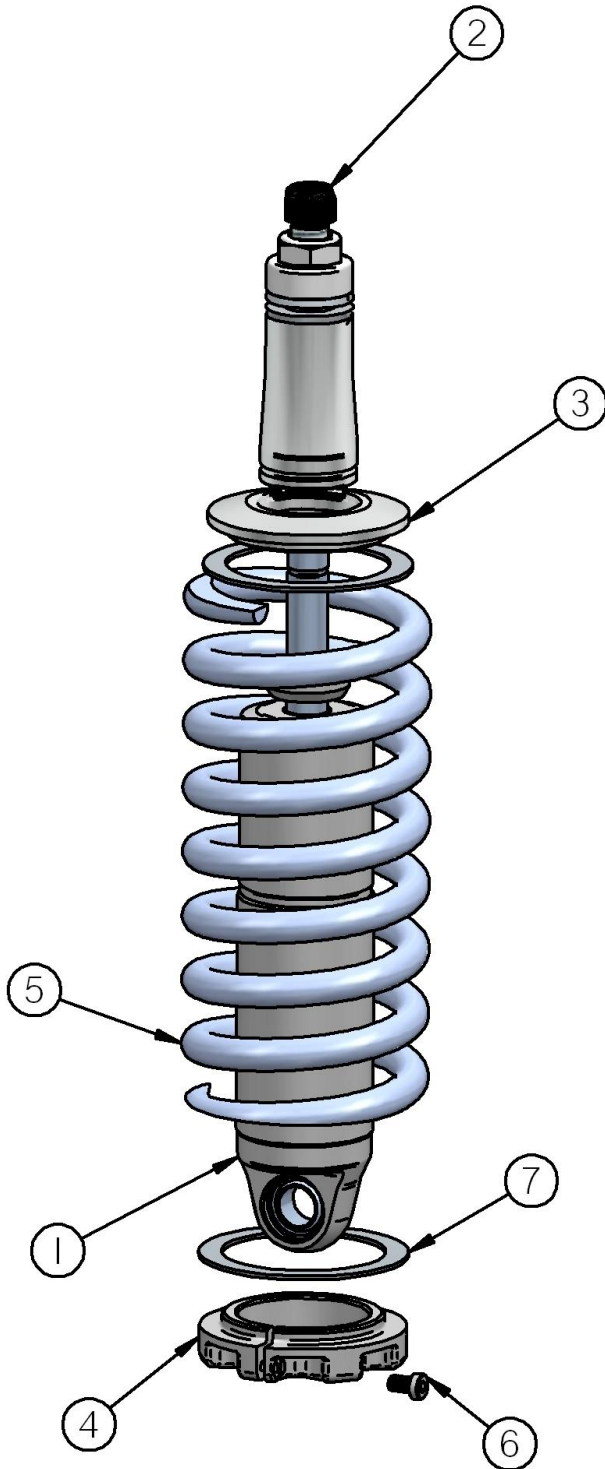

1. Impact Forged, Monotube shock
2. Rebound adjustment knob (SA Only)
3. Upper coil spring retainer
4. Lower coil spring retainer
5. High tensile coil spring
6. Set screw
7. Delrin Spring Washer

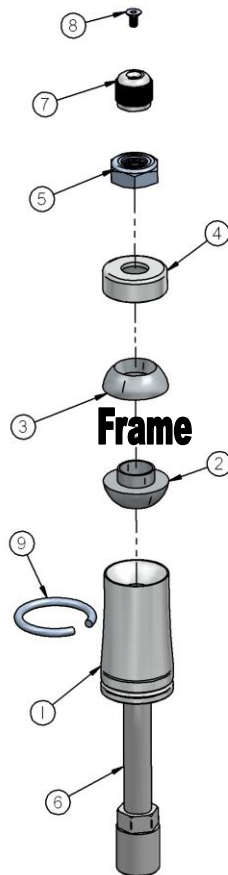

1. Stud top base
2. Lower Delrin ball half
3. Upper Delrin ball half
4. Aluminum cap
5. 9/16" Nylok jam nut
6. Threaded stud
7. Adjustment knob (SA Only)
8. Screw
9. Snap ring

# COILOver

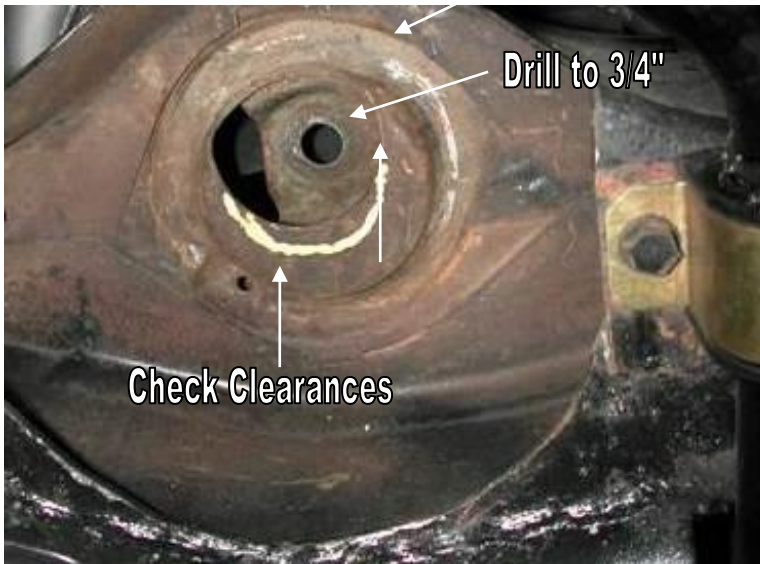

1. Inspect the factory welds attaching the upper shock bracket to the frame. Re-weld if necessary.
2. To allow the step in the lower Delrin ball half to slide into the factory shock hole, the hole will need to be drilled out to  $\frac{3}{4}$ ".
3. Assemble the CoilOver then place into the coil spring pocket w/ the stud and lower Delrin ball sticking through the factory shock hole.



4. Check clearance between the upper spring retainer and stud base with the factory coil spring retainer this area may need trimmed to get full shock movement.
5. Place the upper Delrin ball over stud, then the aluminum cap. Secure the assembly w/ the  $\frac{9}{16}$ " Nylok jam nut.

**TIGHTENING THE TOP  $\frac{9}{16}$ "-18 NUT:** SNUG THE NUT DOWN AGAINST THE TOP CAP. YOU NEED TO BE ABLE TO ARTICULATE THE SHOCK BY HAND. WE TORQUE THE NUT TO 80 INLBS USING A  $\frac{7}{8}$ " CROWS FOOT WRENCH ON A TORQUE WRENCH.

6. Attach the bottom of the shock to the lower StrongArms using the spacers and hardware supplied w/ the arm.

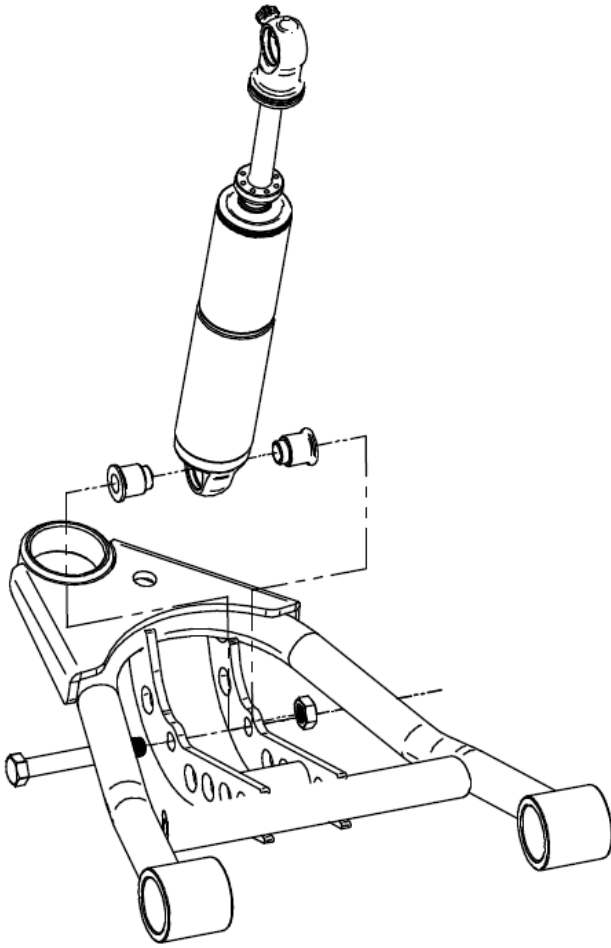

3. Check clearance between the upper factory spring retaining lip and stud top base. Allowing this to hit could cause the shock to break, this area may need to be trimmed for full shock movement.

4. Place the upper Delrin ball over stud, then the aluminum cap. Secure the assembly w/ the 9/16" Nylok jam nut.

5. Attach the bottom of the shock to the lower StrongArms using the spacers and hardware supplied w/ the arm.

# ridetech

## COIL-OVER

### Ride Height

We have designed most cars to have a ride height of about 2" lower than factory. To achieve the best ride quality & handling, the shock absorber needs to be at 40-60% overall travel when the car is at ride height. This will ensure that the shock will not bottom out or top out over even the largest bumps. Measuring the shock can be difficult, especially on some front suspensions. Measuring overall wheel travel is just as effective and can be much easier. Most cars will have 4-6" of overall wheel travel. One easy way to determine where you are at in wheel travel is to take a measurement from the fender lip (center of the wheel) to the ground. Then lift the car by the frame until the wheel is just touching the ground, re-measure. This will indicate how far you are from full extension of the shock. A minimum of 1.5" of extension travel (at the wheel) is needed to ensure that the shock does not top out. If you are more than 3" from full extension of the shock then you are in danger of bottoming out the shock absorber.

### Adjusting Spring Height

When assembling the CoilOver, screw the spring retainer tight up to the spring (0 preload). After entire weight of car is on the wheels, jounce the suspension and roll the car forward and backward to alleviate suspension bind.

- If the car is too high w/ 0 preload then a smaller rate spring is required. Although threading the spring retainer down would lower the car, this could allow the spring to fall out of its seat when lifting the car by the frame.
- If the car is too low w/ 0 preload, then preload can then be added by threading the spring retainer up to achieve ride height. On 2.6" - 4" stroke shocks, up to 1.5" of preload is acceptable. On 5-7" stroke shocks, up to 2.5" of preload is acceptable. If more preload is needed to achieve ride height a stiffer spring rate is required. Too much preload may lead to coil bind, causing ride quality to suffer.

### Shock adjustment 101- Single Adjustable

#### Rebound Adjustment:

How to adjust your new shocks.

The rebound adjustment knob is located on the top of the shock absorber protruding from the eyelet.

You must first begin at the ZERO setting, then set the shock to a soft setting of 20.



-Begin with the shocks adjusted to the ZERO rebound position (full stiff). Do this by rotating the rebound adjuster knob clockwise until it stops.



-Now turn the rebound adjuster knob counter clock wise 20 clicks. This sets the shock at 20. (settings 21-24 are typically too soft for street use).

#### Take the vehicle for a test drive.



-if you are satisfied with the ride quality, do not do anything, you are set!



-if the ride quality is too soft increase the damping effect by rotating the rebound knob clock wise 3 clicks. CONTINUE ON NEXT PAGE.

# ridetech

## Take the vehicle for another test drive.



-if the vehicle is too soft increase the damping effect by rotating the rebound knob clock wise 3 additional clicks.

-If the vehicle is too stiff rotate the rebound adjustment knob counter clock wise 2 clicks and you are set!

Take the vehicle for another test drive and repeat the above steps until the ride quality is satisfactory.

### **Note:**

**One end of the vehicle will likely reach the desired setting before the other end. If this happens stop adjusting the satisfied end and keep adjusting the unsatisfied end until the overall ride quality is satisfactory.**

## Shock adjustment 101- Triple Adjustable

### **Triple Adjustable:**

#### **Step One: High Speed Compression**



-High speed compression adjustments are used in both street driving and track tuning.

-Begin with the shocks adjusted to the ZERO high speed compression position (full stiff). Do this by rotating the high speed compression adjuster (large knob) clockwise until it stops.

-Now turn the high speed compression adjuster knob counter clock wise 20 clicks. This sets the shock at 20. (settings 21-24 are typically too soft for street use. For typical street driving the high speed compression adjuster will remain at setting 20.

#### **Step Two: Low Speed Compression**

Low speed compression adjustment is what is typically felt during street driving.



-Begin with the shocks adjusted to the ZERO low speed compression position (full stiff). Do this by rotating the low speed compression adjuster (small knob) clockwise until it stops.

-Now turn the low speed compression adjuster knob counter clock wise 20 clicks. This sets the shock at 20. (settings 21-24 are typically too soft for street use). Take the vehicle for a test drive.

-if you are satisfied with the ride quality, do not do anything, you are set!

-if the ride quality is too soft increase the damping effect by rotating the low speed compression knob clock wise 3 clicks.

## Take the vehicle for another test drive.



-if the vehicle is too soft increase the damping effect by rotating the low speed compression knob clock wise 3 additional clicks.

-If the vehicle is too stiff rotate the low speed compression adjustment knob counter clock wise 2 clicks and you are set!

Take the vehicle for another test drive and repeat the above steps until the ride quality is satisfactory.

### **Step 3:**

Adjust rebound according to Single Adjustable instructions.

### **Note:**

**One end of the vehicle will likely reach the desired setting before the other end. If this happens stop adjusting the satisfied end and keep adjusting the unsatisfied end until the overall ride quality is satisfactory.**