



350 S. St. Charles St. Jasper, In. 47546  
Ph. 812.482.2932 Fax 812.634.6632

[www.ridetech.com](http://www.ridetech.com)

**Part # 11140298**  
**65-70 Buick Fullsize/66-70 Riviera Air Suspension System**

**Front Components:**

1 11142401 HQ Series Shockwave Kit

**Rear Components:**

1 11144099 Rear CoolRide Kit for Stock Lower Arms

1 11140701 HQ Series Rear Shocks



**Part # 11142401**

**65-70 Buick Full Size, 66-70 Riviera Front HQ Shockwave, OEM Control Arms**

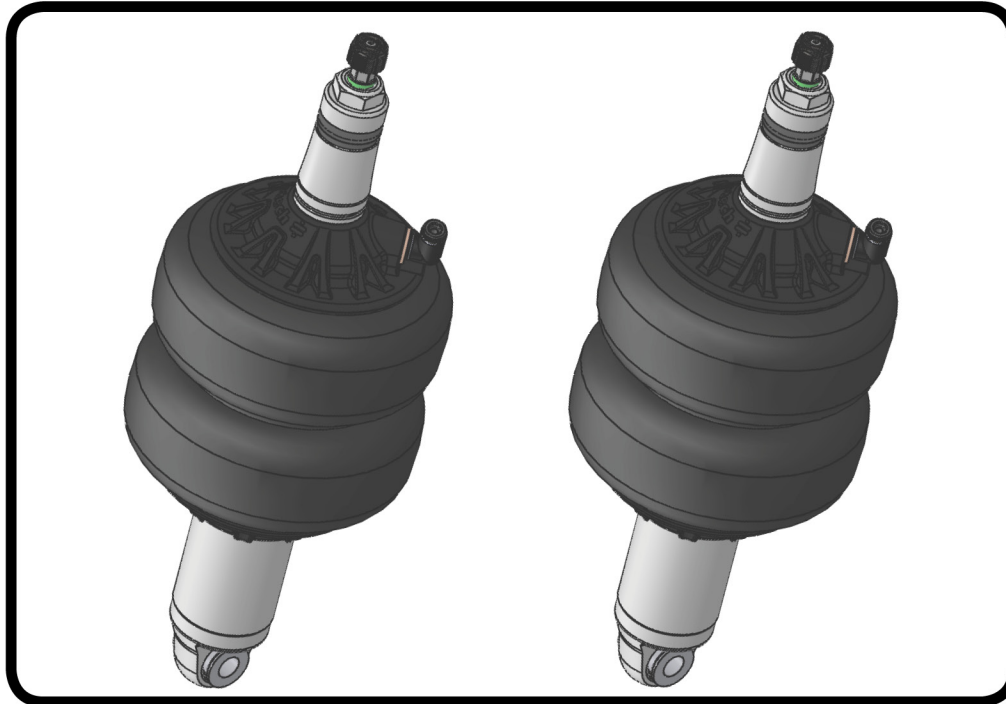

Recommended Tools



## **1000 Series Bellow, 2.75" Stud/.500" Bearing 2.9" Shock Installation Instructions**

### Table of contents

Page 2..... Included components

Page 3-4..... Shockwave Installation

Page 5-6..... Notes and Care of Your Shockwave & Shock Adjustment

### ShockWave Dimensions:

#### Mount to Mount:

Compressed: 10.35"

Ride Height: 11.75"

Extended: 12.65"

THE DELRIN BALL REQUIRES A 3/4" HOLE FOR THE FLANGE TO GO THROUGH. THIS CAN BE DRILLED WITH A UNIBIT.

[www.ridetech.com](http://www.ridetech.com)  
812-482-2932

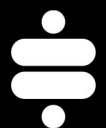



### Major Components .....In the box

Item #	Part #	Description	QTY
1	24129999	2.9" Stroke HQ Series Shock	2
2	90009989	2.75" Stud Top (Installed on Shock) - Includes Adjuster Knob & Screw	2
3	24090199	1000 Series 6.5" Double Convolute AirSpring	2
4	70010893	AirSpring Locking Ring (Installed on shock)	2
5	99055000	Locking Ring Set Screw (Installed on shock)	2
6	90002041	1/2" ID Bearing Spacer (1" over all width)	4
7	90002313	2.75" Aluminum Stud Top Base	2
8	90001904	Bottom Delrin Ball	2
9	90001903	Top Delrin Ball	2
10	90001902	Delrin Ball Aluminum Top Cap	2
11	99562003	9/16"-18 Thin Nylok Nut	2
12	90009972	Adjuster Knob - (90009989 assembly)	2
13	90009969	#4-40 X 1/4" SS, 18-8 Pan Head Torx Cap - (90009989 assembly)	2
14	90000706	Control Arm Spacers	4
	70012161	2.75" Stud Top Metering Rod (installed in stud top)	2
	90001994	5/8" ID Bearing (installed in shock and eyelet)	4
	90001995	Bearing Snap Ring (installed in shock and eyelet)	8
	99501034	1/2"-13 X 4 1/4" Hex Bolt	2
	99502009	1/2"-13 Nylok Nut	4

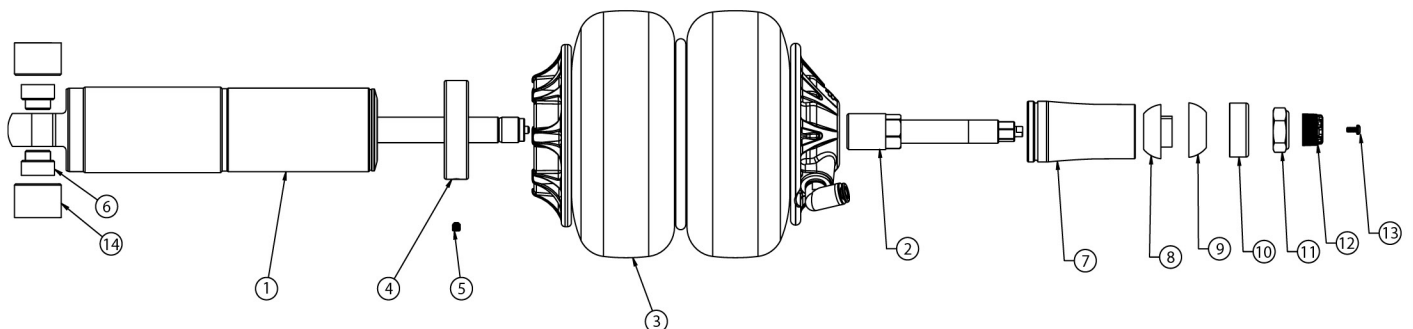

**THE DELRIN BALL REQUIRES A 3/4" HOLE FOR THE FLANGE TO GO THROUGH. THIS CAN BE DRILLED WITH A UNIBIT.**

**WARNING: ATTEMPTING TO REMOVE THE AIR FITTING WILL DAMAGE IT AND VOID THE WARRANTY.**



### ShockWave Installation

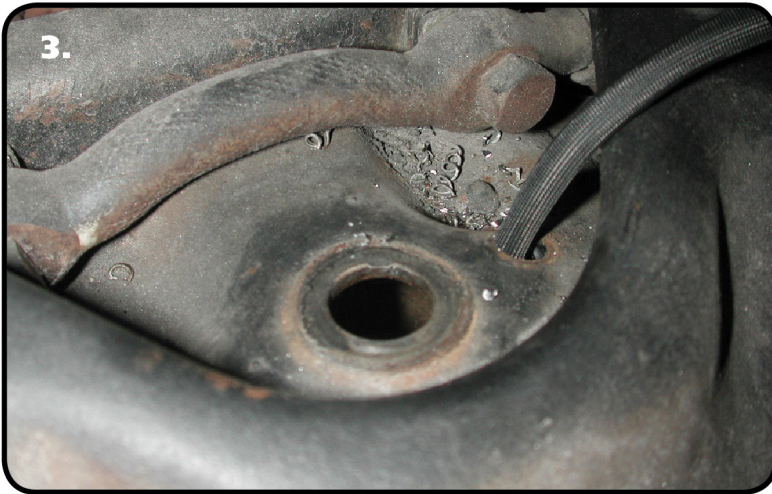

1. Raise and support vehicle at a safe, comfortable working height. Let the front suspension hang freely.

2. Remove the coil spring and shock absorber. Refer to factory service manual for proper disassembly procedure.

3. The upper shock hole needs drilled to 3/4". A Unibit works well for drilling the hole.



4. To allow for proper Shockwave clearance, so trimming must be done the lip around the coil spring pocket. This can be done with a die grinder and cut off wheel.

**Note:** It will be helpful to temporarily install the shockwave before cutting to see exactly what must be trimmed. Mark the frame then remove Shockwave before cutting.

**Allowing the Shockwave to touch the frame at any point through full suspension travel will damage the unit and is not warrantable.**



5. The lower shock mount hole will be used to mount the Shockwave. This hole must be drilled out to 1/2".



### ShockWave Installation

6.

1. Stud top aluminum base
2. Delrin ball lower half
3. Delrin ball upper half
4. Aluminum cap
5. 9/16" SAE Nylok jam nut
6. Threaded stud (screwed onto shock shaft)
7. Rebound adjusting knob
8. Screw

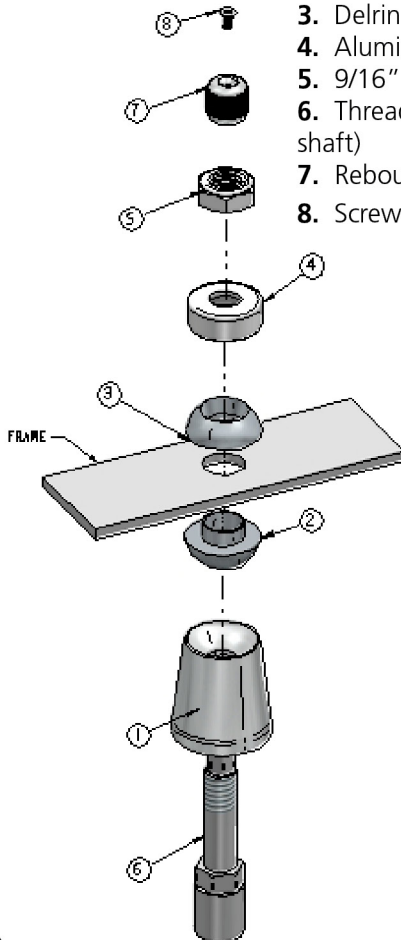

**Note:** The airline must also be routed at this time. It can be ran through the subframe toward the rear of the vehicle.

6. Apply thread sealant to a 90 degree air fitting and screw it into the top of the Shockwave. The air fitting location can be rotated by twisting the bellow assembly separate of the shock. Place the Shockwave into the coil spring pocket with the stud sticking through the OEM shock hole. See assembly **Diagram 6**. OEM Shock hole **must** be drilled out to  $\frac{3}{4}$ "

1. Stud top aluminum base
2. Delrin ball lower half
3. Delrin ball upper half
4. Aluminum cap
5. 9/16" SAE Nylok jam nut
6. Threaded stud (screwed onto shock shaft)
7. Rebound adjusting knob
8. Screw

**THE CONTROL ARMS NEED TO BE REINFORCED IN THE AREA THAT THE TRUNNION BOLTS TO.**

7. Raise the lower arm up to the Shockwave. Insert a 90000706 Spacer on each side of the Shock Bearing lining up all the holes. Attach the ShockWave to the control arm using the 1/2" x 4 1/4" Bolts, & Nylok Nuts supplied with the ShockWaves. Torque to 75 ftlbs.

8. Raise the lower control arm to full compression and double-check to make sure the Shockwave does not rub on anything at anytime. Allowing the Shockwave to rub on anything will cause failure and is not a warrantable situation.

9. Ride height should be around 110-115 psi but will vary to vehicle weight and driver preference.





### Notes and Care of your Shockwaves

#### NOTES:

**WARNING: ATTEMPTING TO REMOVE THE AIR FITTING WILL DAMAGE IT AND VOID THE WARRANTY.**

**TIGHTENING THE TOP 9/16"-18 NUT:** SNUG THE NUT DOWN AGAINST THE TOP CAP. YOU NEED TO BE ABLE TO ARTICULATE THE SHOCK BY HAND. WE TORQUE THE NUT TO 80 INLBS USING A 7/8" CROWS FOOT WRENCH ON A TORQUE WRENCH.

You can clock the airfitting location on the ShockWave by turning the AirSpring assembly of the shock. Make sure the fitting doesn't contact the frame.

When cutting the airline, use a razor blade. The cut needs to be a clean cut and square for the airline to seal properly.

The Locking ring on the shock is **NOT** adjustable. These rings are set at the factory to optimize the AirSpring stroke with the shock stroke.

---

## The care and feeding of your new ShockWaves

1. Although the ShockWave has an internal bumpstop, **DO NOT DRIVE THE VEHICLE DEFLATED RESTING ON THIS BUMPSTOP. DAMAGE WILL RESULT.** The internal bumpstop will be damaged, the shock bushings will be damaged, and the vehicle shock mounting points may be damaged to the point of failure. This is a non warrantable situation.
2. Do not drive the vehicle overinflated or "topped out". Over a period of time the shock valving will be damaged, possibly to the point of failure. This is a non warrantable situation! If you need to raise your vehicle higher than the ShockWave allows, you will need a longer unit.
3. The ShockWave is designed to give a great ride quality and to raise and lower the vehicle. **IT IS NOT MADE TO HOP OR JUMP!** If you want to hop or jump, hydraulics are a better choice. This abuse will result in bent piston rods, broken shock mounts, and destroyed bushings. This is a non warrantable situation.
4. Do not let the ShockWave bellows rub on anything. Failure will result. This is a non warrantable situation.
5. The ShockWave product has been field tested on numerous vehicles as well as subjected to many different stress tests to ensure that there are no leakage or durability problems. Failures have been nearly nonexistent unless abused as described above. If the Shockwave units are installed properly and are not abused, they will last many, many years. ShockWave units that are returned with broken mounts, bent piston rods, destroyed bumpstops or bushings, or abrasions on the bellows will not be warrantied.



### Shock Adjustment

#### Shock adjustment 101- Single Adjustable

##### Rebound Adjustment:

How to adjust your new shocks.

The rebound adjustment knob is located on the top of the shock absorber protruding from the eyelet.

You must first begin at the ZERO setting, then set the shock to a soft setting of 20.



-Begin with the shocks adjusted to the ZERO rebound position (full stiff). Do this by rotating the rebound adjuster knob clockwise until it stops.



-Now turn the rebound adjuster knob counter clock wise 20 clicks. This sets the shock at 20. (settings 21-24 are typically too soft for street use).

##### Take the vehicle for a test drive.



-if you are satisfied with the ride quality, do not do anything, you are set!

-if the ride quality is too soft increase the damping effect by rotating the rebound knob clock wise 3 clicks. **CONTINUE ON NEXT PAGE.**

##### Take the vehicle for another test drive.



-if the vehicle is too soft increase the damping effect by rotating the rebound knob clock wise 3 additional clicks.



-If the vehicle is too stiff rotate the rebound adjustment knob counter clock wise 2 clicks and you are set!

Take the vehicle for another test drive and repeat the above steps until the ride quality is satisfactory.

##### Note:

**One end of the vehicle will likely reach the desired setting before the other end. If this happens stop adjusting the satisfied end and keep adjusting the unsatisfied end until the overall ride quality is satisfactory.**

### STILL HAVE QUESTIONS?

#### Tech line hours

Monday - Friday

8AM - 6PM (EST) ..... 812-482-2932



350 S. St. Charles St. Jasper, In. 47546  
Ph. 812.482.2932 Fax 812.634.6632  
[www.ridetech.com](http://www.ridetech.com)

**Part # 11144099**  
**65-70 Buick Fullsize & 66-70 Riviera Rear CoolRide**

**Components:**

2	90009002	Tapered sleeve air spring
2	90000708	Upper air spring cup bracket
2	90000224	Upper washer (Medium)
2	90000291	Lower washer (Small)
2	90000290	Air spring roll plate (Large)
1	90000707	Carrier bearing spacer

**Hardware:**

2	99435005	7/16" x 3 3/4" stud	Upper mount to frame (Cut down to 2 1/2")
2	99432001	7/16" Nylok nut	Upper mount to frame
2	99433002	7/16" SAE flat washer	Upper mount to frame
4	99371001	3/8" x 3/4" USS bolt	Air spring to upper mount
2	99371003	3/8" x 1" USS bolt	Air spring to lower mount
6	99373005	3/8" lock washer	Air spring
6	99373003	3/8" SAE flat washer	Air spring
4	99311002	5/16" x 1 1/4" USS bolt	Carrier bearing
4	99312003	5/16" USS Nylok nut	Carrier bearing
8	99313002	5/16" SAE flat washer	Carrier bearing

# COOL RiDE®

## Installation Instructions

1. Raise the vehicle to a safe and comfortable working height with the suspension hanging freely.
2. Remove the factory shock absorbers and coil spring. Refer to a factory service manual for proper disassembly procedures.

**\*\*\* Must Use RideTech Shock Kit \*\*\***



3. To allow the lower piston of the air spring to seat down into the coil spring retainer, the top of the retainer must be trimmed off.



4. Apply thread sealant an elbow air fitting and screw it into the top of air spring.

5. Bolt the upper bracket to the top of the air spring using two 3/8" x 3/4" USS bolts, lock washers and flat washers. Then bolt the fasten the upper bracket to the frame using the 2 1/2" stud, Nylok nut and flat washer.

6. Place the 5 1/4" OD x 2 3/4" ID plate over the coil spring retainer. Then slide the lower piston of the air spring down over the coil spring retainer. Secure the assembly with the 2 1/2" washer, a flat washer, lock washer and 3/8" x 1" bolt.



7. Replace the factory shocks with the new ones supplied.

8. To correct the drive line angle we have supplied carrier bearing spacers. These will be installed between the carrier bearing cross member and the frame. 5/16" x 1 1/4" bolts flat washers and Nyloks are also supplied.

9. Ride height on this air spring is approximately 8" tall.

# ridetech

350 S. St. Charles St. Jasper, In. 47546

Ph. 812.482.2932 Fax 812.634.6632

[www.ridetech.com](http://www.ridetech.com)

**Part # 11140709**

**65-70 Buick Fullsize & 66-70 Riviera  
RQ Series Rear Shock Kit**

**Shock:**

2	22989999	HQ Smooth Body Shock Cartridge
2	70011139	5/8" ID Shock Bushing
2	70011138	3/4" ID Shock Bushing
2	90002103	5/8" ID Shock Sleeve
2	90002068	Wide Trunnion

**Components:**

2	90000471	Aluminum shock spacer
2	90001619	Shock stud

**Hardware:**

4	99311001	5/16" x 1" USS bolt	Shock to frame
8	99313002	5/16" SAE flat washer	Shock to frame
4	99312003	5/16" USS Nylok nut	Shock to frame

# ridetech

## Installation Instructions



1. Attach the upper T-bar to the frame in the OEM location using the supplied 5/16 x 1" USS bolts, washers and Nylok nuts.



2. Attach the shock to the axle using the new cantilever pin supplied.

# ridetech

350 S. St. Charles St. Jasper, In. 47546  
Ph. 812.482.2932 Fax 812.634.6632  
[www.ridetech.com](http://www.ridetech.com)

## Shock adjustment 101- Single Adjustable

### Rebound Adjustment:

How to adjust your new shocks.

The rebound adjustment knob is located on the top of the shock absorber protruding from the eyelet or stud top. You must first begin at the ZERO setting, then set the shock to a street setting of 12.



-Begin with the shocks adjusted to the ZERO rebound position (full stiff). Do this by rotating the rebound adjuster knob clockwise until it stops.

-Now turn the rebound adjuster knob counter clock wise 12 clicks. This sets the shock at 12. (settings 21-24 are typically too soft for street use).

### Take the vehicle for a test drive.



-if you are satisfied with the ride quality, do not do anything, you are set!

-if the ride quality is too soft increase the damping effect by rotating the rebound knob clock wise 3 clicks.

### Take the vehicle for another test drive.

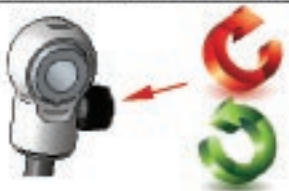

-if the vehicle is too soft increase the damping effect by rotating the rebound knob clock wise 3 additional clicks.

-if the vehicle is too stiff rotate the rebound adjustment knob counter clock wise 2 clicks and you are set!

Take the vehicle for another test drive and repeat the above steps until the ride quality is satisfactory.

### Note:

One end of the vehicle will likely reach the desired setting before the other end. If this happens stop adjusting the satisfied end and keep adjusting the unsatisfied end until the overall ride quality is satisfactory.