



FM0107PC SBC Mid-mount Alternator Bracket

Tools Required:
1/4" Allen Wrench
5/16" Allen wrench
1/2" Open End Wrench
9/16" Open End Wrench
3/8-16 Thread Chaser (If necessary)
New Water pump to Engine block gaskets
RTV silicone sealer
Anti-Seize

We recommend applying Anti-Seize to all threads when assembling bracket.

Recommended Belt: Goodyear 6 Rib #4060407 (40.75") to #4060410 (41") or Dayco #5060408 (40.8") to #5060410 (41")

- 1) Disconnect battery.
- 2) Remove water pump and existing accessory drive brackets; scrape any remaining gasket material from all surfaces.
- 3) Clean & prep threads on passenger side cylinder head (outside hole) and left side of water pump. Run a 3/8-16 thread chaser if necessary. Thread chasers are available at your local auto parts store or tool dealer and are different from a thread cutting tool.
- 4) Thread the 3/8-16 x 1-1/4" threaded stud into the outside passenger side cylinder head and finger tighten. There should be no more than 5/8" of thread left exposed (if more than 5/8" thread is showing, remove stud and clean out threads then reinstall threaded stud and check again). Apply anti-seize to the exposed threads on the stud.
- 5) Thread the 3/8-16 x 2-1/2" threaded studs into the passenger side water pump mount holes and tighten. The studs can easily be tightened by threading two 3/8-16 nuts (not included) onto the stud and tighten them against each other to act as a drive nut. Apply RTV sealer to engine block and water pump.
- 6) Install gaskets and then water pump. There should be no more than 5/8" of thread left exposed on studs (if more than 5/8" thread is showing, remove stud(s) and clean out threads then reinstall threaded stud(s) and check again). Apply anti-seize to the exposed threads on the studs. Also apply anti-seize to the threads of all the remaining fasteners at this time.
- 7) Replace right side water pump bolts and thread the two 2-25/32" spacer nuts with the hex end outward to the studs on the passenger side of the water pump and tighten firmly.
- 8) Thread the 3-11/32" spacer nut to the stud on the passenger side cylinder head and tighten firmly.
- 9) Attach the alternator bracket to the water pump spacer nuts with the two 3/8-16 x 3/4" stainless socket head cap screws and finger tighten.
- 10) Thread the 3/8-16 x 1" stainless socket head cap screw through one end of the turnbuckle assembly and into the lower water pump boss and tighten firmly. Allow the turnbuckle to swing down and rest out of the way.

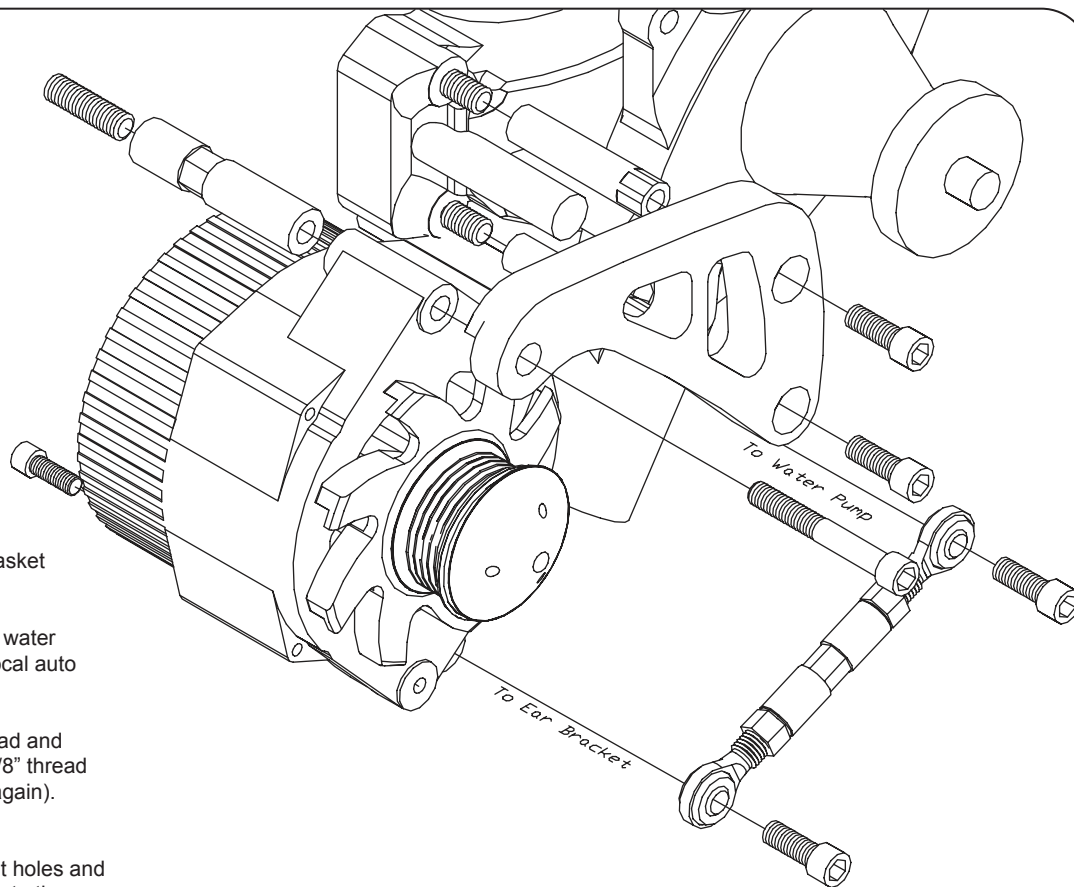

- 11) Attach the alternator ear bracket to the back of the alternator boss with the 5/16-18 x 3/4" stainless socket head cap screw and tighten (26 ft. /lb.).
- 12) Place the alternator between the spacer nut and alternator bracket and thread the 3/8-16 x 2-3/4" stainless socket head cap screw through the Alternator bracket & alternator into the spacer nut and finger tighten.
- 13) Swing the alternator into position and match up the alternator ear bracket to the turnbuckle assembly, thread the 3/8-16 x 1" stainless socket head cap screw through the turnbuckle rod end into the alternator ear bracket and tighten (46ft. /lb.).
- 14) Route belt around alternator, water pump and crank pulleys. Twist turnbuckle by hand until proper belt tension is achieved. Do not over-tighten belt! Serious damage may occur to the accessory drive bearings resulting in premature wear.
- 15) Tighten jam nuts on turnbuckle, tighten alternator socket head screw (46ft. /lb.) and tighten alternator bracket screws on water pump (46ft. /lb.) Re-check belt tension.
- 16) Reconnect electrical and test run motor. Re-check belt tension after 100 miles.





3/8-16 x 1-1/4"
Threaded Stud

3-11/32" Spacer Nut

3/8-16 x 2-1/2" Threaded Stud

2-25/32" Spacer Nut

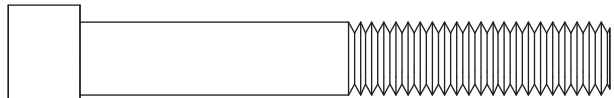

3/8-16 x 2-3/4" Socket Head Cap Screw (x1)

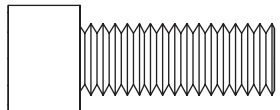

3/8-16 x 1" Socket Head Cap Screw (x2)

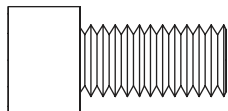

3/8-16 x 3/4" Socket Head Cap Screw (x2)

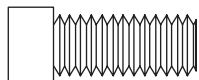

5/16-18 x 3/4" Socket Head Cap Screw (x1)

5/16-18 x 3/4" SHCS

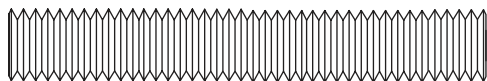

3/8-16 x 2-1/2" Threaded Stud (x2)

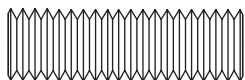

3/8-16 x 1-1/4" Threaded Stud (x1)



2-25/32" Spacer Nut (x2)

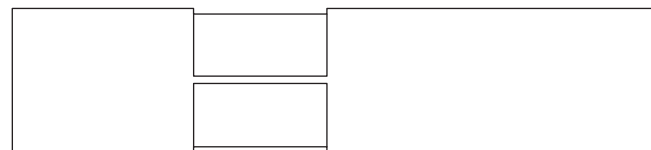

3-11/32" Spacer Nut (x1)

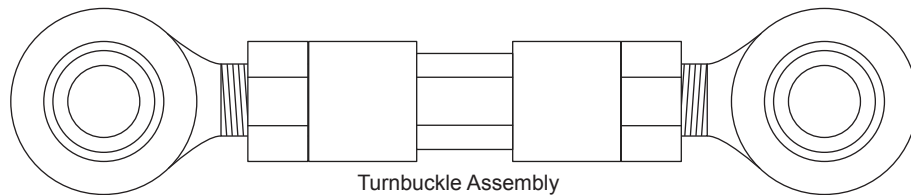
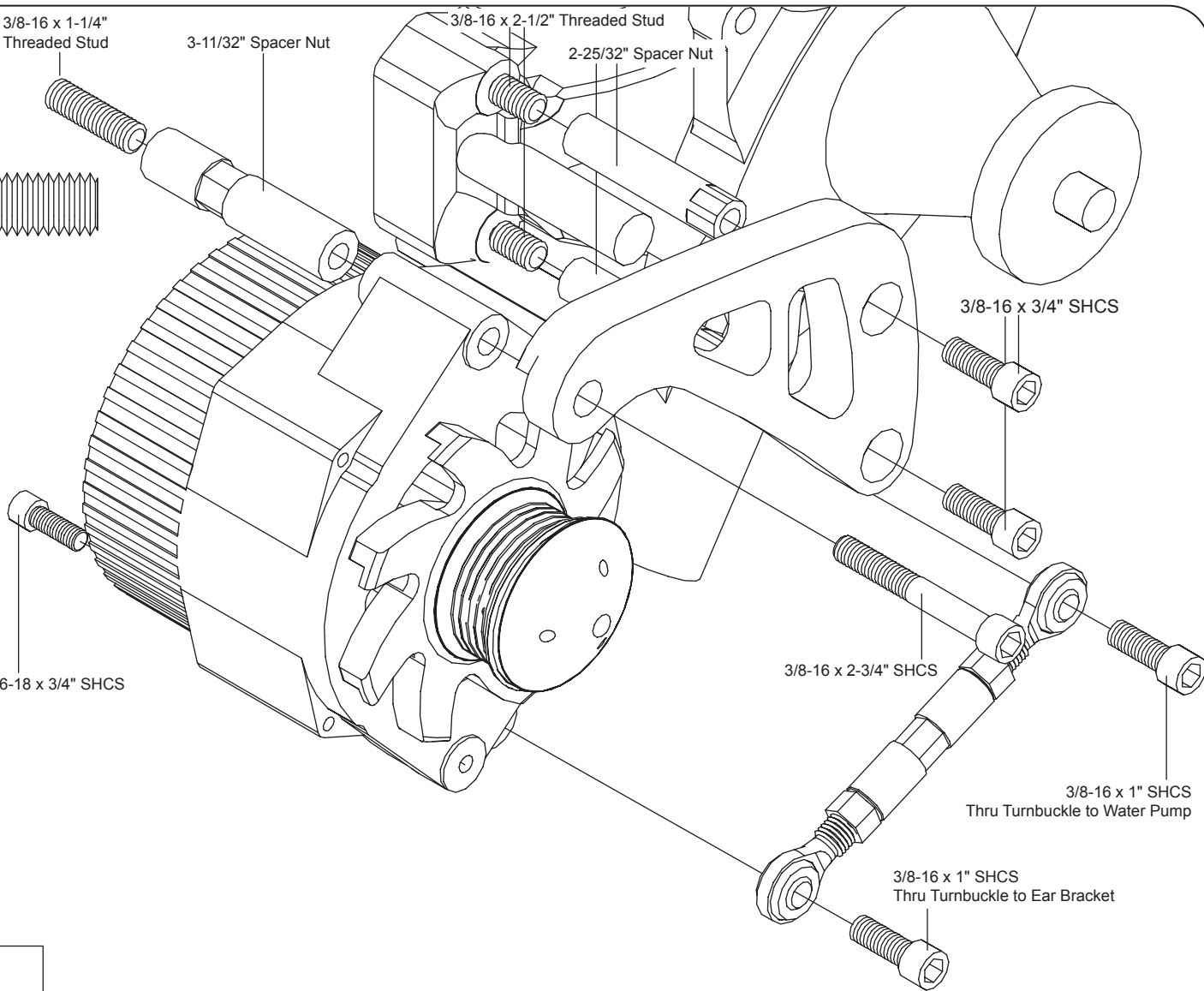

Turnbuckle Assembly